The Measurement of the Rate of Heat-Loss at Body Temperature by Convection, Radiation, and Evaporation

Leonard Hill, O. W. Griffith and Martin Flack

Phil. Trans. R. Soc. Lond. B 1916 **207**, 183-220
doi: 10.1098/rstb.1916.0005

Email alerting service

Receive free email alerts when new articles cite this article - sign up in the box at the top right-hand corner of the article or click [here](#)

To subscribe to *Phil. Trans. R. Soc. Lond. B* go to: <http://rstb.royalsocietypublishing.org/subscriptions>

V. *The Measurement of the Rate of Heat-Loss at Body Temperature by Convection, Radiation, and Evaporation.**

By LEONARD HILL, *F.R.S.*, O. W. GRIFFITH, and MARTIN FLACK.

(*From the Department of Applied Physiology, Medical Research Committee.*)

Received September 27,—Read November 25, 1915.

Introduction.

THE purpose of the research detailed in the following pages has been :—

- (1) To investigate rate of cooling of (1) a dry and (2) a wet surface at body temperature under varying atmospheric conditions, using the kata-thermometer—an instrument contrived by one of us (L. H.) for this purpose ;
- (2) To calibrate this instrument so that the rate of cooling can be expressed in millicalories per second at body temperature ;
- (3) To separate and measure the cooling produced in still air by (*a*) convection, (*b*) radiation, (*c*) evaporation ;
- (4) To measure the cooling effect of wind of varying known velocity, and to calibrate the kata-thermometer as an anemometer—an observation of value since this instrument is sensitive not only to a uni-directional stream, but to every eddy, such as cannot be estimated by any vane anemometer ;
- (5) To measure the effect on the rate of cooling of variations in the barometric pressure ;
- (6) To deduce from the readings of the wet and dry kata-thermometer, taken in still air, the rate of evaporation from a wet surface at body temperature, and to establish the relation of this rate of evaporation to (*a*) vapour pressure, (*b*) barometric pressure, and (*c*) temperature of the atmosphere ;

* The mathematical part of this paper is due to O. W. GRIFFITH; the experimental observations being carried out by us. The death of O. W. GRIFFITH has robbed us and the Physics Department of the London Hospital Medical College of his valued help. We are much indebted to Prof. C. H. LEES, *F.R.S.*, who has been kind enough to read the paper, which was practically complete at the time of O.W.G.'s death. He has given us the help of his criticism and also references to several physical papers which were unknown to us.—L. H. and M. F.

VOL. CCVII.—B 339.

2 D

[Published February 21, 1916.]

- (7) To determine how this rate of evaporation is affected by wind of varying known velocity ;
- (8) By these means to arrive at a method of measuring the relative rates of heat-loss to which the skin is exposed by convection, radiation and evaporation, under varying atmospheric conditions.

For purposes of controlling the heating and ventilation of rooms the thermometer has been used and has acquired an authority which it does not deserve. The dry bulb thermometer indicates the average temperature of the piece of wood to which it is attached, influenced, as it is, by the temperature of all the objects around it and the atmosphere in which it is suspended. It affords no measure of the rate of cooling of the human body, and is, therefore, a very indifferent instrument for indicating atmospheric conditions which are comfortable and healthy to man.

It is not the actual temperature of the air but the rate of cooling which affects the cutaneous nerve endings, by determining the difference between the temperature of the surface of the skin and the blood temperature in the deeper layers. The amount of blood in the cutaneous vessels, the rate of evaporation of water from the skin, and the moistness of the skin surface influence our sensations of comfort or discomfort. The ceaseless variation in the rate of cooling, as in outdoor conditions, relieves us from monotony. A bracing wind cools the skin, tones up the muscles of the body, voluntary and involuntary, and impels us to take exercise to keep warm. The augmented metabolism leads to increased oxidation of food-stuffs, deeper ventilation of the lungs, more efficient massage of the belly organs by the deeper breathing and muscular exercise, better appetite, more perfect digestion and less bacterial decomposition in the bowels, more vigorous circulation of the blood, thus in every way promoting health. Physiological research has shown that it is not the chemical purity, but the physical conditions of the atmosphere which act so potently upon us. It is the disaffection, or monotonous stimulation, of the vast field of cutaneous and nasal nerves on the *outside* of the body, not the absorption of poisonous inhaled products into the blood, which occasion the discomfort of badly ventilated and crowded rooms. Monotony of the atmospheric conditions and the reduction of the body metabolism by diminished rate of cooling, with consequent loss of nervous tone and disordered digestion, are, we believe, the chief causes of the ill effects of confined sedentary occupations. The workers in such occupations are exposed to massive bacterial infection from the carriers of disease, coupled with a reduction of immunity resulting from their sedentary occupation in over-heated windless air, contaminated, as it may be, with products of imperfect combustion, and with a dust which predisposes to infection. This enfeebled state of health, together with massive infection, causes the epidemics of respiratory disorders, so prevalent in winter. Outdoor workers, exposed to cold and inclement weather, are singularly free from such affections. It is, then, of the first importance that there should be a means of measuring the rate of cooling, and

estimating in this respect the difference between the atmospheric conditions to which men are exposed, outdoors and indoors, in tropical, temperate and arctic climates.

Searching the literature we have discovered that nearly a century ago a Dr. HEBERDEN⁽⁸⁾, suggested the importance in estimating comfortable and healthy conditions, of measuring the rate of cooling at body temperature by heating up a thermometer and measuring the time it took to cool through a degree or two. His valuable conception fell into oblivion. Rate of cooling has been studied by physicists, but not by hygienists. Against HEBERDEN'S method was the fact that no two thermometers are alike in their heat capacity as measured by their water equivalent. When one of us (L. H.) independently conceived this method of enquiry and introduced the kata-thermometer he thought that the same glass blower working to scale might turn out bulbs sufficiently like to give the same readings. Experience of the first batch of instruments confirmed this view, for the kata-thermometers cooled under the same conditions in approximately the same time. Further investigation, however, has shown that other batches of instruments, and even those of the same batch, may vary, and that it is necessary to calibrate each instrument by determining its water equivalent.

We have come across two other investigators who have made efforts to measure rate of cooling from the hygienic point of view. KISSKALT⁽¹⁷⁾, in order to investigate rooms of uneven temperature, used a glass bulb filled with mercury in which was immersed a thermometer. He measured the water equivalent of the apparatus; it was about 120 calories. He heated his instrument and determined the time it took to cool each degree from 170° F. downwards. He does not seem to have further developed this line of enquiry. J. R. MILNE⁽²¹⁾ contrived an instrument which he termed a psychrainometer (*ψυχραίνω* I become cold) which traces on a moving paper strip a continuous record of electrical heating needed to maintain at blood heat a body freely exposed to the atmosphere. Using in conjunction with this an anemometer and self-recording thermometer he deduced an empirical formula giving the rate of cooling as a function of temperature and wind velocity.

Neither of these investigators seems to have paid any attention to the rate of cooling of the wet instrument, which is of the greater physiological importance.

*The Kata-thermometer.**

The kata-thermometer—by means of which the observations recorded in this investigation were taken—is an instrument designed primarily for the measurement of its own rate of cooling when its temperature approximates to that of the human body. It consists of an alcohol thermometer with a cylindrical bulb about 4 cm. long and 2 cm. diameter, and a stem 20 cm. in length graduated in fifths of a degree

* The instrument may be obtained from Mr. J. Hicks, 8, Hatton Garden, E.C.

Fahrenheit from 90° – 110° F. The base terminates in a small reservoir which serves the double purpose of acting as a safety overflow reservoir in case of accidental over-

heating of the bulb and of enabling the instrument to be heated well above the point at which observation has to be made in order to give time for transferring it to a suitable position for reading, and also to ensure that, by then, it has settled down to a regular rate of cooling. The distance of the top graduation mark (110) from the reservoir is about 13 cm. For the purposes of taking the wet readings the bulb is covered with a "glove" of open mesh cotton material,* and, after dipping the instrument in hot water until the spirit rises just into the reservoir, the superfluous water is shaken off before replacing the kata-thermometer in position for reading. The object being to determine the cooling power of the air in the neighbourhood of 98° F., it is essential that the thermal capacity of the bulb should be such that the cooling is neither too fast nor too slow to be measured with accuracy. This means that the errors in reading the thermometer and the stop-watch must be of the same order. To determine how far that is practicable, our preliminary investigations were directed towards examining the behaviour of the instrument under all possible conditions of temperature and humidity of the atmosphere surrounding it.

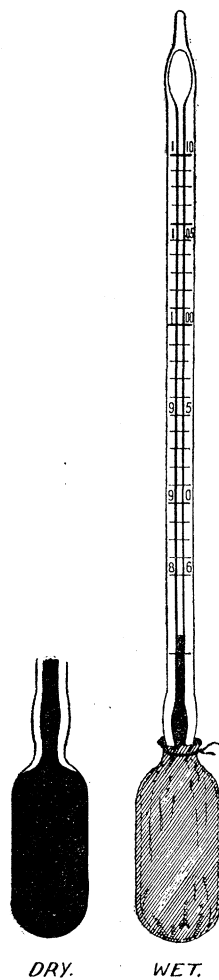

Fig. 1.

Preliminary Investigations.—Owing to the size of the bulb we experienced some difficulty at the start in obtaining an enclosure sufficiently big for its general mean temperature to remain constant while a series of observations were being taken, on account of the tendency of the kata-thermometer to heat up the surrounding air. After some trials the chamber described was constructed and found to answer the purpose exactly.

The chamber was a cube of 17 inches. The water jacket surrounding it communicated with a tube leading to the hot and cold water supply. The jacket in the detachable front communicated with that surrounding the rest of the chamber, so that the whole was filled with water at the same temperature. The jacket was emptied by detaching the tube from the hot and cold supply, and letting the water run out into the sink. By these means the chamber could quickly be brought to any required temperature. A tube passed to the bottom of the jacket, and by blowing air through this the water in the jacket could be stirred during the taking of observations. In the front of the chamber were inserted two glass observation discs through which, by means of a laryngoscope mirror and a lamp, the instruments

* *E.g.*, the finger of a lady's "Lisle thread" glove.

within the chamber could be illuminated and read. Within the chamber were suspended (1) wet- and dry-bulb thermometers, (2) the kata-thermometer. To make an observation the kata-thermometer was heated up outside the chamber, and then introduced through a tubular orifice. The orifice was plugged by a rubber cork to which the kata-thermometer was attached.

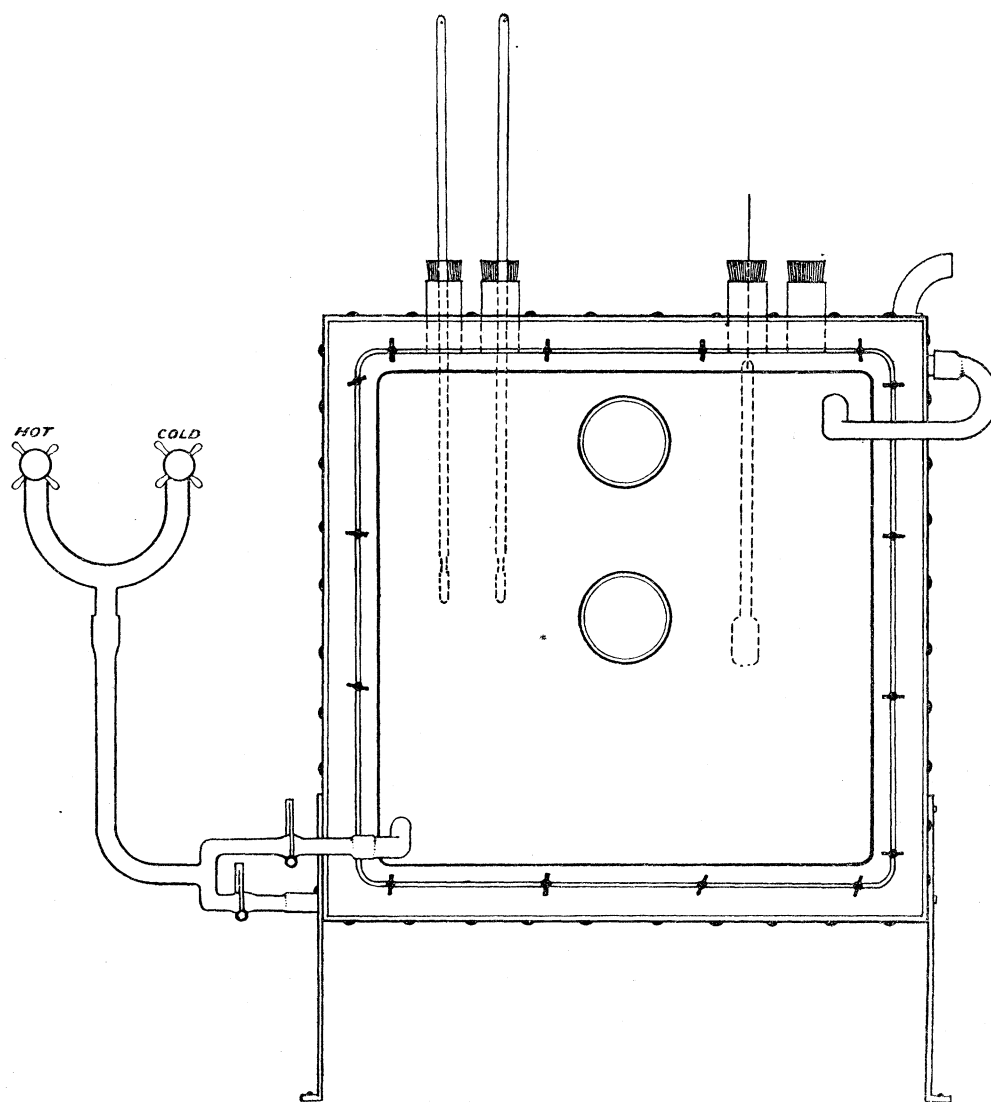

Fig. 2.

A series of experiments was then carried out according to the following plan, whereby a large number of different conditions were obtained by variation of temperature and humidity of the air in the chamber. This scheme was generally adopted in the subsequent exact measurement of cooling power in quiet air detailed in this paper.

TABLE I.—Temperatures and Humidities of Still Air in which Measurements were made.

Temperature of chamber.	Approximate percentage humidity.
° C.	} 20, 40, 60, 90, 100
5	
10	
15	
20	
25	
30	
35	
40	

Figs. 5 (p. 196) and 13 (p. 208) show a few of the cooling curves representing particularly the extreme conditions realised in the range covered by the above plan. It will be observed that, in the case of the dry-bulb kata, the graphs are straight in the region 100°–95° F. for a considerable range. This permits of the application of NEWTON'S law of cooling in its simplest form—the rate of cooling is proportional to the difference of temperature between the cooling body and its environment—to the calculation of the rate of cooling at 98° F., approximately the temperature of the human body. In cases where the temperature of the enclosure was high, the cooling was so slow that the time could be read off on the stop-watch, for a cooling from 99°–97° F. or a smaller range than that, if necessary. In this circumstance also the portion of the graph dealt with is practically straight. Fig. 13 indicates clearly that the wet katagraphs remain almost straight throughout, except where the air was nearly saturated at a high temperature.

The general method adopted, then, for taking the readings was to time the cooling from 100°–95° F. in the majority of cases, but to calculate over a smaller range when the cooling was slow.

Operating in this way, some thousands of readings were obtained, which form the basis of the conclusions we have arrived at.

Theoretical Considerations.

In previous investigations of the cooling power of the air, undertaken solely from the physical point of view, from the classical researches of DULONG and PETIT to the more recent experiments of P. COMPAN⁽³⁾—most authors have been satisfied with the determination of the “velocity of cooling,” rather than with the actual rate of loss of heat. Owing to this, as will be shown by the theory worked out below, it is impossible to compare the results of different investigators, and their results fail to give complete knowledge of all the factors involved in the process of cooling by convection. In the

present research all results are expressed in heat unit per square centimetre of bulb surface per second, and it is found convenient to adopt a unit of heat the thousandth part of a calorie—or a millicalorie. This convention enables us to enumerate the reductive factor of the kata-thermometer to the degree of accuracy warranted by the observations in figures which are free from any decimal fractions. The methods adopted for calibrating the instrument so as to express the results in the unit mentioned are next described.

Determination of Water Equivalent of Kata-Thermometer.

We have emphasised the desirability of expressing rate of cooling in heat unit rather than as “velocity” of cooling or rate of loss of temperature. In order to do this it became necessary to determine the water equivalents of the kata-thermometers that were employed. This in itself proved to be no easy matter though the difficulties were eventually completely overcome. It was recognised at the outset that the water equivalent of such an instrument is a variable quantity on account of gradual accumulation of more liquid in the bulb on cooling and an uncertain amount of leakage of heat by conduction along the stem. These and other considerations coupled with the fact that rates of cooling were calculated at a certain fixed temperature, namely $36^{\circ}5$ C., imposed on any method adopted the condition that the water equivalent should be determined while the column of liquid was in the neighbourhood of the 100 division on the stem. Two methods were used for this purpose.

Method I.—This was the ordinary electro-calorimetric method. The kata-thermometer bulb was immersed in water in a copper calorimeter which was enclosed in a

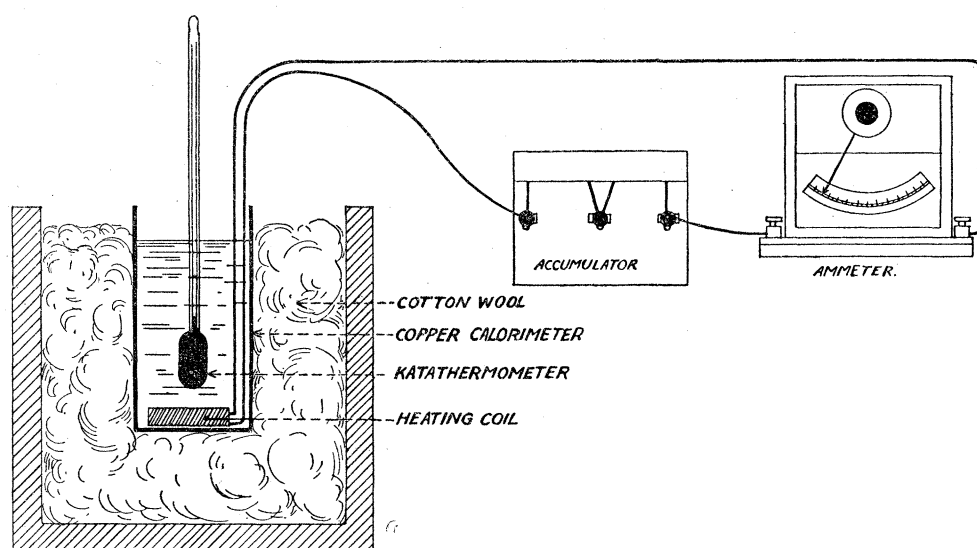

Fig. 3.

larger vessel, the space between them being filled up with loosely packed cotton-wool. Inside the copper calorimeter was a manganese heating coil about 4 ohms resistance

and this was in circuit with accumulators, an ammeter and an adjustable rheostat. Two sets of readings were taken. The first set determined the heat required to change the temperature of the whole from room temperature (about 15° C.) up to about division 95° F. on the kata-thermometer. The second set measured the heat involved in raising the temperature from room temperature to division 100 or thereabouts on the kata-thermometer. The radiation corrections were obtained and applied in the usual way by taking the rate of cooling of the calorimeter and contents before and after heating. These corrections, under the condition of the experiment, were small. After allowing for the water equivalent of the calorimeter and contained water the value of the water equivalent of the kata-thermometer was found to be 3.61 in grammes.

Method II.—When, as in the course of our work, it became necessary to know the water equivalent of half-a-dozen or more instruments the above method was found to be rather tedious. In order to facilitate rapid determinations the following method was developed. The kata-thermometer, after being heated in the ordinary way, was placed to cool inside a zinc gauze cage (double walled if necessary), and its time of

cooling through the range 100° – 95° F. observed. The gauze cage placed in the quiet air of the room afforded a sufficient protection from draughts while it allowed free convection and thus served to maintain a constant temperature inside while observations were being made. The times of several instruments could thus be taken within the space of half-an-hour. Before and after such a series of readings, a metal instrument of known water equivalent was allowed to cool under the same condition and its time noted. This metal instrument was a cylindrical copper pot of the same dimensions as the bulb of the kata-thermometer. Its water equivalent was 1.16. At two ends of a diameter of it respectively an iron wire and a Eureka wire were soldered, thus making the pot a thermo-junction measuring its own temperature. This arrangement was joined up with a compensating junction and galvanometer as in the case of our dew-point apparatus, fig. 11, so that temperature could be read

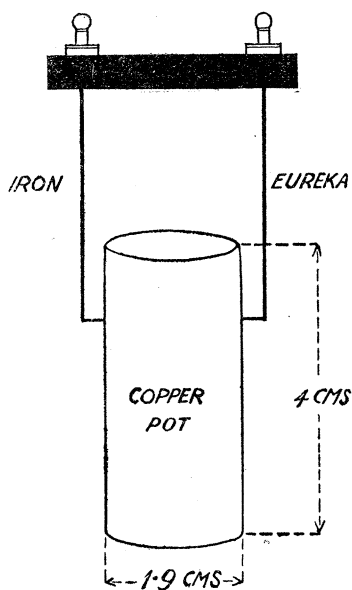

Fig. 4.

correct to a thirtieth of a degree if necessary. The inside of the pot was filled loosely with cotton-wool. In order to ensure that the emissivity of the pot was the same as the average value for the kata, the two instruments, heated to the same temperature, were arranged one on each side of a thermopile and at equal distances from it. Their surface areas being the same, their radiations could be compared. The pot was painted over with successive thin coatings of dull black varnish until its radiating power was approximately equal to that of the kata-thermometer. It was found quite easy to make this adjustment. The time of cooling of the pot in the gauze cage over the

given range was then determined, and the water equivalent of the kata-thermometer calculated from the ratio of the times. The value obtained for the same instrument as that previously quoted was 3.62 gr. The agreement between the results is quite satisfactory, and method II. was finally adopted as the standard method for quick calibrations of kata-thermometers.

In actual practice it is, for many reasons, better to calculate the rate of heat-loss per square centimetre, and hence the proper constant to adopt is the water equivalent per unit area. This was easily calculated for the copper pot, on account of its cylindrical form, and from the ratio of the times it could as easily be determined for the kata-thermometer without having to measure the area of the bulb.

In order, however, to be able to convert the readings of any kata-thermometer into millicalories per square centimetre per second we have adopted a converting number which we call its kata-factor. It is a number such that the required result is obtained by dividing it by the time of cooling from 100°–95° F. on the kata scale.

If T_1 = time of cooling of kata, in seconds,

T_2 = time of cooling of copper pot over same range.

Then the water equivalent per unit area of kata-thermometer bulb

$$= \frac{1.16}{7.04 \times \pi} \cdot \frac{T_1}{T_2},$$

where

1.16 = water equivalent of copper pot,

7.04π = surface area of copper pot,

and the kata-factor is given by

$$\begin{aligned} K &= \frac{5 \times 5 \times 1.16}{9 \times 7.04 \times \pi} \cdot \frac{T_1}{T_2} \times 1000 \\ &= 145 \frac{T_1}{T_2}. \end{aligned}$$

For an air temperature of 16° C., T_2 was 45 seconds.

Method III.—Having in this way standardised the kata-thermometer and having demonstrated, as is shown later, that the equation of the curve expressing the relation between H (the heat lost from the kata at body temperature in calories per square centimetre per second) and θ (the difference in temperature between the kata and its surroundings), is in a quiet atmosphere,

$$H = 0.27\theta = 0.27(36.5 - t),$$

we see that, for instruments made to the same pattern, the kata-factor can now be determined much more readily. It is only necessary to determine the time of cooling

in still air from 100–95°, and the temperature of the air t ; if this time be ϕ seconds then

$$\frac{K}{\phi} = H = 0.27 (36.5 - t),$$

or

$$K = 0.27 (36.5 - t)\phi.$$

As already indicated in our opening paragraphs the rate of cooling of the wet katha-thermometer depends on convection, evaporation, and radiation, and it is one of the fundamental objects of our enquiry not only to separate these three factors, but also to determine in what way each of them depends on the physical properties of the surrounding environment.

Convection.

There is a valuable historical survey of the experimental treatment of the problem of free convection given by COMPAN⁽³⁾ in the paper already cited, and also by KING⁽¹⁶⁾. It is unnecessary here to cover the same ground again. Two or three points, however, require to be emphasised because they bear directly on the object of the present enquiry. We have already stated that most experimenters on the rate of cooling of a thermometer in an enclosure maintained at constant temperature have been satisfied with the measurement of the velocity of cooling, *i.e.*, with the rate of loss of temperature.

This was all very well so long as the same instrument was used for all observations. J. VINCENT, in his account of “Nouvelles Recherches sur la Température Climatologique,” considers this fact a fatal objection to HEBERDEN’s work (*loc. cit.*), and suggests that a possible way of overcoming the difficulty would be for all investigators adopting the rate of cooling method to have their thermometers made to the same pattern by the same maker. As already mentioned, our experience does not support this contention, for katha-thermometers made to the same pattern differ so much in their water equivalents that comparison of results obtained with different instruments is out of the question unless the same have been properly standardised.

It is essential, therefore, for the sake of scientific precision, to express the rate of cooling in heat units per second. Uncertainty arising from changes in the temperature of the surrounding air in the cooling enclosure must also be avoided, and it is not clear how far that condition was secured in the researches referred to. Another important omission in the historical survey of COMPAN is the absence of any reference to the theoretical treatment of the problem of convection. It surely is very necessary to know in what way the rate of cooling depends on the various constants characterising the physical nature of the atmosphere. Not merely to know that the phenomenon arises in different gases, but to investigate why and how it is affected by

the density, specific heat, thermal conductivity, and viscosity. This aspect of the question has not received the attention it deserves, and the standard textbooks ignore even the attempts at solution which have been offered. Difficulty of the problem cannot be a sufficient reason, as it compares in that respect quite favourably with the question of conduction of heat in solids.

An approximate solution of the problem of convection from the surface of the kata-thermometer bulb may be derived as follows. Suppose the bulb is cylindrical and that its axis is vertical. Taking this as an axis of reference, then, when the steady state is reached, we can write POISSON'S equation for the flow of heat

$$\rho'sw \cdot \frac{\partial \theta}{\partial z} = k \frac{\partial^2 \theta}{\partial r^2} + \frac{1}{r} \cdot \frac{\partial \theta}{\partial r} + \frac{\partial^2 \theta}{\partial z^2} \dots \dots \dots (1)$$

where s = specific heat, ρ' = density, w = velocity, $(T + \theta)$ = absolute temperature, k = conductivity at any point (r, z) ; T being the absolute temperature of the air at an "infinite" distance from the bulb. If ρ is the density at T^0 , then $\rho' = \rho \frac{T}{T + \theta}$.

Substituting this value in (1), multiplying by ∂z and integrating from $z = 0$ to $z = l$, where l = length of bulb we get

$$\frac{s\rho w}{k} \cdot T \cdot \log \frac{T + \theta}{T} = \frac{l}{r} \cdot \frac{\partial}{\partial r} \left(r \frac{\partial \theta}{\partial r} \right) \dots \dots \dots (2)$$

This assumes that $\frac{\partial \theta}{\partial z}$ is zero at the two limits and that w is constant for a constant value of r . It also leaves out of account any "end corrections" which would be relatively small in the case of a tolerably long bulb.

If we further neglect all terms of the second and higher orders in the expansion of $\log \frac{T + \theta}{T}$ the equation simplifies into

$$\frac{s\rho w}{k} \cdot \theta = \frac{l}{r} \cdot \frac{\partial}{\partial r} \left(r \frac{\partial \theta}{\partial r} \right) \dots \dots \dots (3)$$

We have in addition to this the equation of motion of the air which, making the same assumption as before, namely that within this limit w is independent of z , reduces to

$$-g \frac{\theta}{T} = \frac{\eta}{\rho} \cdot \frac{T + \theta}{T} \cdot \frac{1}{r} \cdot \frac{\partial}{\partial r} \left(r \cdot \frac{\partial w}{\partial r} \right) \dots \dots \dots (4)$$

η being the coefficient of viscosity. These equations are similar to those derived by L. LORENZ⁽²⁰⁾ for a flat strip. His solution, of course, is not applicable in this case.

For the solution of equations (2), (3) and (4), put

$$r = r_0 + \alpha \log \frac{\theta_0}{\theta},$$

where

r_0 = radius of the bulb,

α = constant,

$T + \theta_0$ = absolute temperature of surface of the bulb.

This satisfies the limiting conditions $r = r_0$ when $\theta = \theta_0$ and $r = \infty$ when $\theta = 0$.

We may also write $w = b (\theta_0 - \theta) \theta$, so that $w = 0$ when $\theta = \theta_0$ and when $\theta = 0$, which are the conditions inferred by the problem. If b is a constant and we write $\frac{dw}{dr} = \frac{\partial w}{\partial \theta} \cdot \frac{\partial \theta}{\partial r}$, then substituting in (4) and evaluating b when $\theta = \theta_0$ and $r = r_0$, we get

$$b = \frac{\alpha^2 g \rho}{3\eta T \cdot \theta_0} \cdot \left(1 - \frac{\theta_0}{T}\right) \left(1 + \frac{\alpha}{3r_0}\right), \dots \dots \dots (5)$$

and from (3) after integrating once, we get

$$b = \frac{6kl}{\alpha^2 \rho s} \cdot \frac{1}{\theta_0^2} \cdot \dots \dots \dots (6)$$

Now H the heat lost per square centimetre per second from the surface of the bulb = $\left[-k \cdot \frac{\partial \theta}{\partial r}\right]_{\theta = \theta_0} = k \frac{\theta_0}{\alpha}$.

From (5) and (6)

$$\alpha^4 = \frac{18\eta T k l}{g \rho^2 s \theta_0} \left(1 + \frac{\theta_0}{T} - \frac{\alpha}{3r_0}\right),$$

the second and third terms within the bracket being small compared with 1.

Hence

$$H = 0.486 \left(\frac{g s k^3}{\eta T l}\right)^{1/4} \cdot \rho^{1/2} \cdot \theta_0^{5/4} \cdot \left(1 - \frac{\theta_0}{4T} + \frac{\alpha}{12r_0}\right) \cdot \dots \dots \dots (7)$$

Neglecting the small terms in the last bracket, and taking for g, s, k , &c. their zero values from KAYE and LABY'S tables, together with their temperature coefficient, the formula reduces to

$$H = 0.0644 (1 + 0.002t) \cdot \theta_0^{5/4},$$

where H is now expressed in millicalories per square centimetre per second and t = temperature of the surrounding air in degrees Centigrade.

TABLE II.—Total Heat-Loss.

H = heat lost in millicalories per square centimetre per second.

θ = excess of temperature at which H is determined (body temperature) above that of the surrounding atmosphere, degrees Centigrade.

These figures were obtained under all possible conditions and with several katha-thermometers. See also fig. 5.

H.	θ .	H.	θ .
5.60	22.4	7.65	28.8
4.51	17.2	8.05	29
3.08	12.1	7.15	26
8.39	31.6	3.70	14.5
8.80	32.8	2.15	8.9
7.91	28.8	1.9	7.7
6.41	23.5	1.04	4.3
4.48	17.3	6.76	26
2.91	11.2	7.04	26.2
3.82	14.2	6.16	23.2
5.17	19.6	4.54	17.9
3.72	14.5	2.80	11.7
2.37	9.31	1.44	6.18
5.22	19.3		

The above table shows that the values of H calculated from equation (7), and as determined experimentally, are in close agreement. Moreover the existence of the correcting factor in (7) and the fact that it involves θ and the dimension of the bulb, possibly explains why DE LA PROVOSTAYE and DESAINS and P. COMPAN have found considerable variation in their temperature and pressure indices. DULONG and PETIT gave 1.233 as the temperature index, while the other experimenters found that this number was a mean around which the experimental values oscillated in an irregular way. It is worthy of mention at this point that we found the rate of cooling of the dry bulb katha-thermometer independent of the degree of moisture—*i.e.*, of the vapour pressure in the enclosure. The reason for this is made clear by the formula (7), for the value of the term $\frac{s\rho^2k^3}{\eta}$ is the same for water vapour as it is for air. This has an important bearing on the interpretation of the readings of the wet katha-thermometer which receives further notice in the section of this paper dealing with evaporation. KENNELLY and SANBORN⁽¹⁵⁾ say the effect of moisture in the air upon the convection of heat from a thin wire seems to be small. They did not measure it. PETAVEL⁽²⁶⁾ found the loss 20 per cent. greater in moist than in dry air.

Another striking fact brought into prominence by the study of the curves in fig. 5 is that the graph connecting rate of total heat-loss in still air and the difference in

196 MESSRS. LEONARD HILL, O. W. GRIFFITH, AND MARTIN FLACK ON THE

temperature between the kata-thermometer and the enclosure is a straight line, the equation of which is

$$H = 0.27\theta.$$

In plotting this curve rates of cooling have been taken over three ranges of the kata-

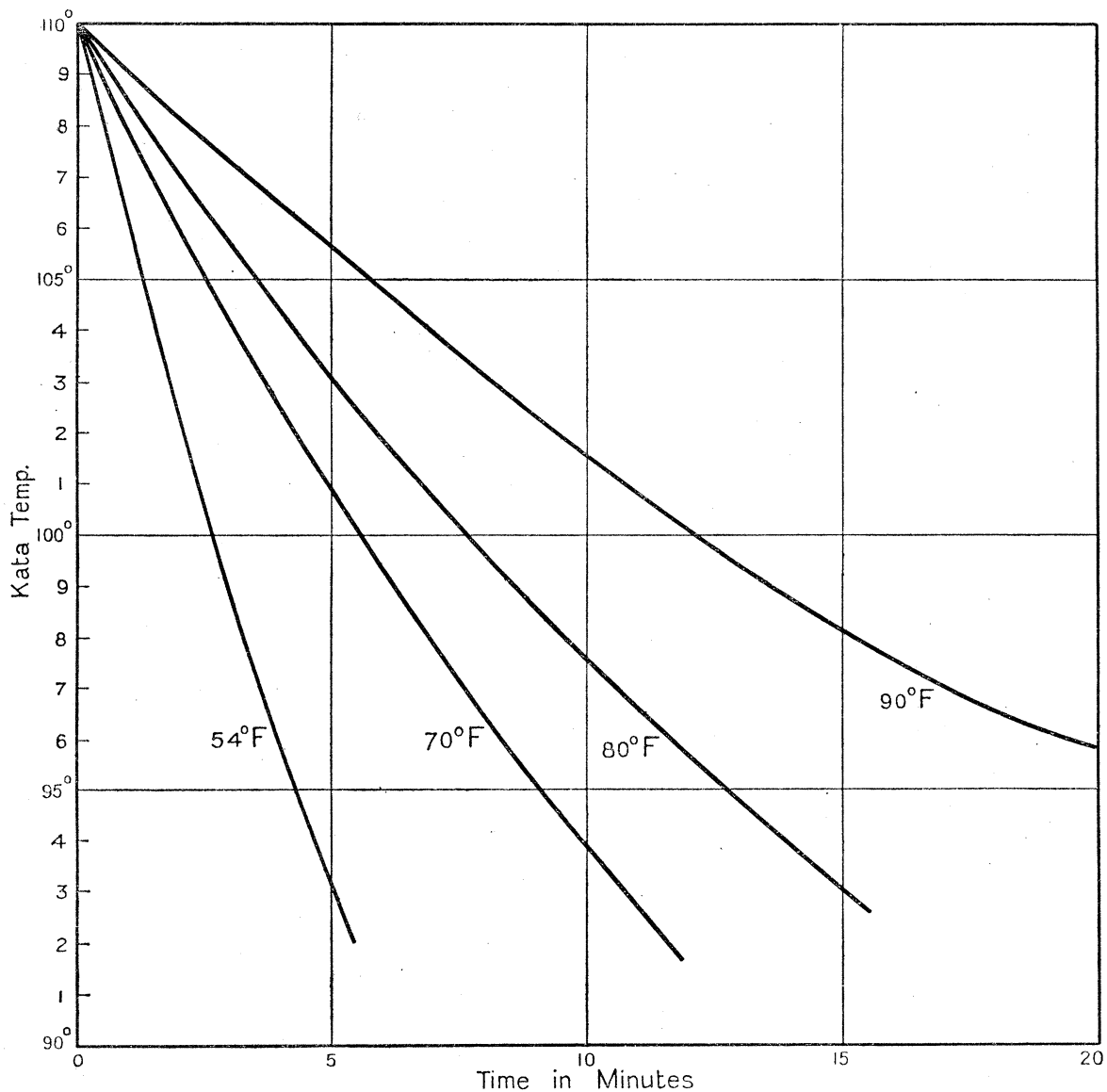

Fig. 5. Dry kata cooling curves for different temperatures of enclosures.

thermometer, namely 105–100, 100–95, 95–90 (in degrees F.) and it is seen (fig. 6) that within the limit of experimental error, all the points lie on or near the straight line. *This means that in the case of the kata-thermometer in still air, within the range indicated, there happens to be such a balance between convection and radiation*

as to make the total heat-loss always directly proportional to the temperature excess.

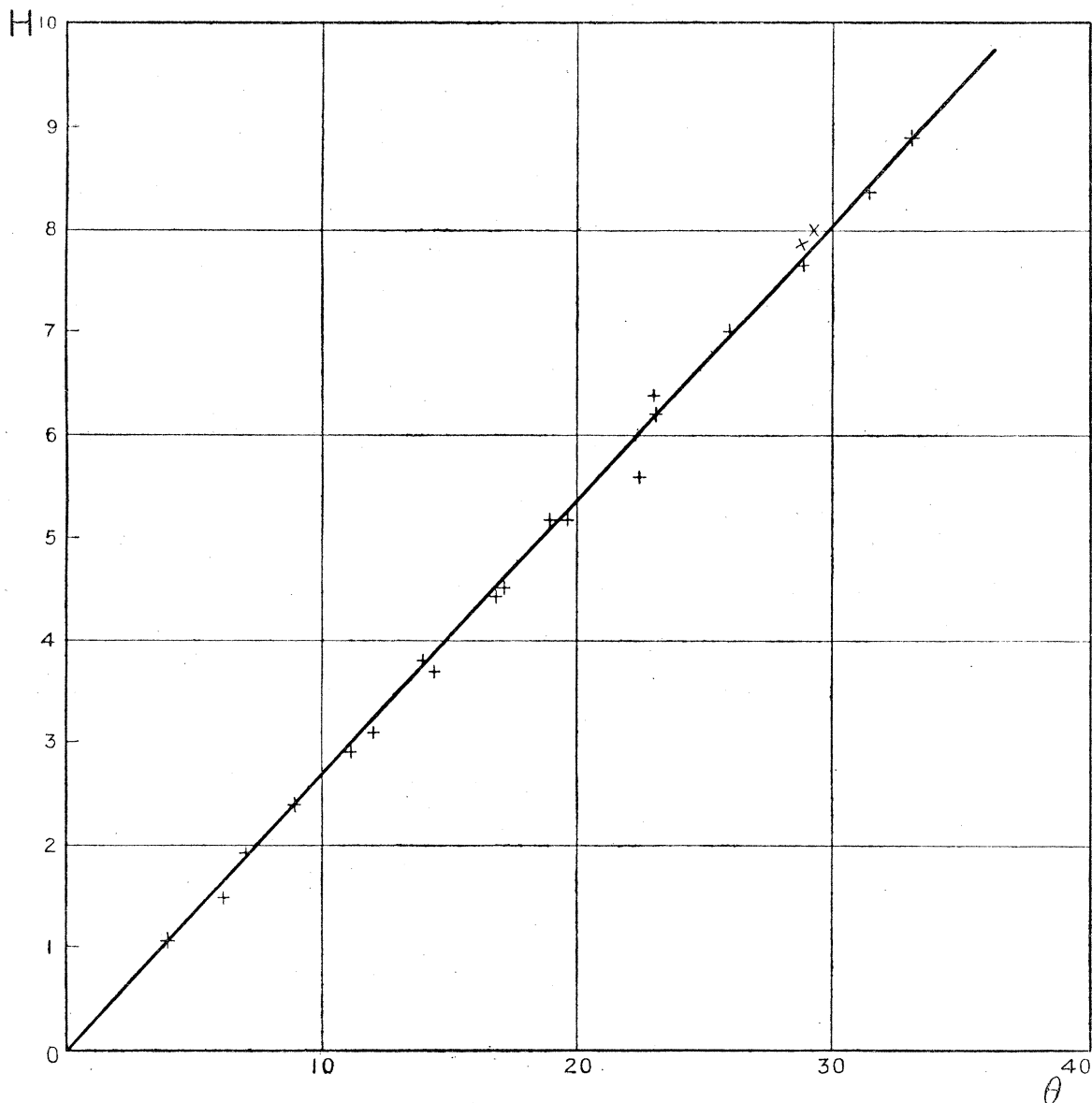

Fig. 6.

H = heat lost in millicalories per square centimetre per second.
 θ = excess of temperature of kata above temperature of air.

Effect of Changes in Atmospheric Pressure on Convection.

The effect of pressure on rate of cooling has received the attention of many physicists since DULONG and PETIT conducted their famous researches.

We are not concerned with the general question in this investigation, and we have

confined our observations to such changes in pressure as usually occur in the atmosphere, mainly with the object of testing the sensitiveness of the kata-thermometer to such changes. To study the effect of varying the barometric pressure we connected a fourth orifice in the roof of the chamber to a pump and a manometer. The front of the chamber was attached in air-tight fashion by the aid of a rubber pneumatic collar and screw nuts. The kata-thermometer was heated up, introduced, and then the barometric pressure was altered to the required extent. According to the theory given above the rate of heat-loss is proportional to the square root of the density, and therefore of the pressure. According to BRUSH⁽²⁾ this is approximately so. Since we may write $H = c\sqrt{p}$ where p = pressure and c is a constant at constant values of bulb and enclosure temperatures, then

$$\frac{\delta H}{H} = \frac{1}{2} \frac{\sqrt{p}}{p}$$

that is to say, the percentage change in rate of heat-loss is one-half the percentage change in pressure. Hence at atmospheric pressures a variation of 3 cm. from normal pressure means a change of 2 per cent. in the rate of loss of heat per square centimetre per second; or 1 cm. pressure change produces 0.67 per cent. change in H . The following table (III.) is a sample of some of our readings, and shows that the kata-thermometer is quite sensitive to variations of about 3 cm. pressure from the normal when it is perfectly protected from draughts.

TABLE III.

Temperature of enclosure.	Pressure, cm. Hg.	Time of cooling, 100–95° F. in seconds.	Percentage change in H per centimetre.	$t\sqrt{p}$.
° C. 16.5	79	97	0.67	173
	73	101		174
16.7	79	95	0.68	169
	76	97		169
17.2	78	105	0.64	185
	72	109		184

The Effect of Wind upon Rate of Cooling.

Fig. 7 shows the arrangement of the apparatus used by us for the investigation of the rate of cooling in air moving at varying and known velocities. A brass tube,

MEASUREMENT OF THE RATE OF HEAT-LOSS AT BODY TEMPERATURE, ETC. 199

4 feet long and 2 inches in diameter was used to ensure freedom from eddies ; air was sucked through this tube, and a meter, by means of a Roots blower. The volume of air drawn through during the time of each observation was indicated by the meter. The volume was varied by varying the speed of the electric motor, and also by opening the side tube, which is shown in the figures closed by a clip. The kata-thermometer was introduced through a tubulure as shown. Wet- and dry-bulb thermometers were inserted through other tubulures and records taken from these before each reading of the kata-thermometer. To vary the temperature we heated up the whole room by means of gas and electric stoves, or drew in the cool outside air in winter time.

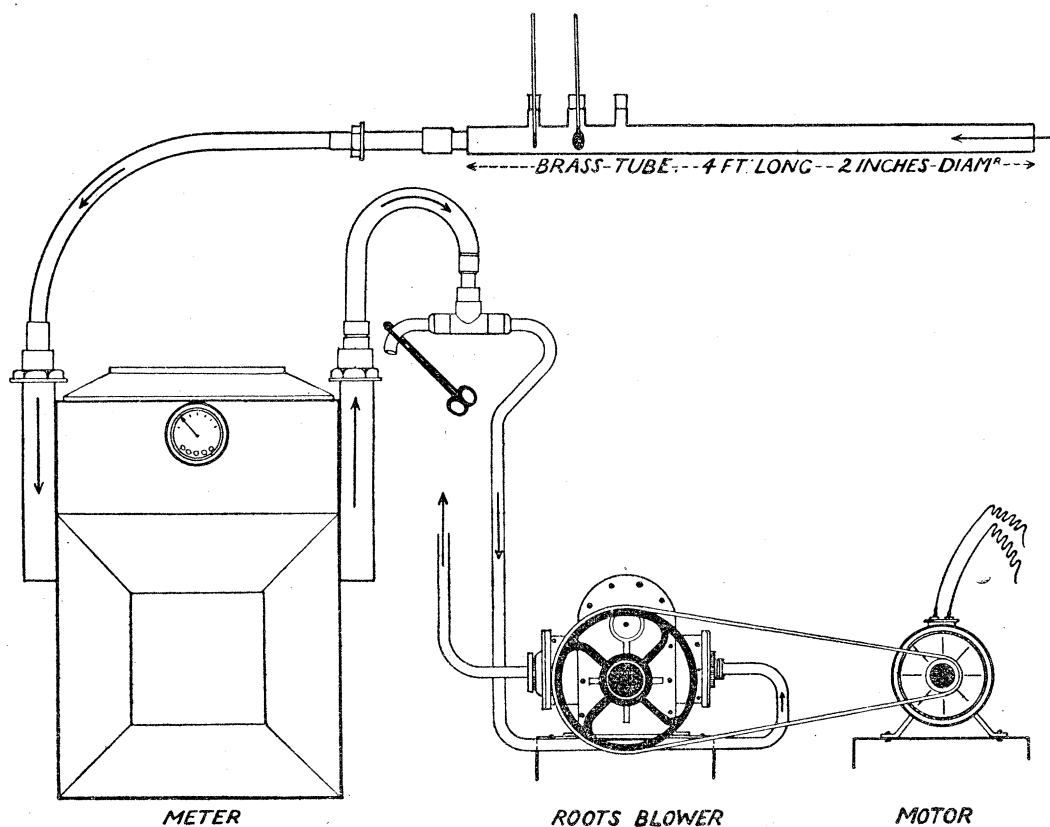

Fig. 7.

The shape of the kata-thermometer enabled us to regard the middle part of it as a cylinder, while the two ends formed together a sphere. Both the sphere and cylinder could be measured, and thus we were able to deduce the amount by which the kata-thermometer diminished the sectional area of the tube, and so calculate the velocity of the wind, *i.e.*, the *mean velocity* over the contracted section of the tube. For the higher wind velocities we used a Keith pressure fan kindly placed at our disposal by Mr. James Keith. The velocities were calculated from the pressure of the air measured by a water manometer.

Theoretical considerations with respect to the effect of the temperature of the air

stream.—Many observers have verified NEWTON'S law of cooling for a wide range. COMPAN measured the velocity of cooling of a copper sphere in currents of air of three different velocities, namely 3, 6, 9 metres per second, and extended his observations to 300° C.*; KENNELLY and his co-workers⁽¹⁴⁾, J. T. MORRIS⁽²³⁾ and others have found the same law to hold good for the cooling of electric wires.

Reference to our results shows that our experiments with the kata-thermometer establishes the temperature law for a wide group of velocities. Theoretically the question of the rate of cooling of a hot body in a fluid stream has been considered by BOUSSINESQ⁽¹⁾, ALEXANDER RUSSELL⁽²⁸⁾ and OSBORNE REYNOLDS⁽²⁷⁾. BOUSSINESQ worked out the cases of a heated strip and also of a cylindrical body cooled by a non-turbulent fluid stream, and enunciated his law that the rate of cooling H and the temperature excess θ and the velocity V are connected by a formula of the type

$$H = K \cdot \theta \cdot \sqrt{V},$$

K being a constant.

RUSSELL gives instructive proofs of the formula as applied to a number of interesting cases, working out the form of the function K in each problem, but limiting himself in the mathematical treatment to stream-line motion of the fluid. When, however, the motion is turbulent, *i.e.*, when the velocity of the fluid exceeds the critical velocity, the above proofs do not apply. It is noteworthy also that they fail for the special case of $V = 0$. But the problem of cooling in a turbulent stream was considered by OSBORNE REYNOLDS, and he suggested that in this case the rate of cooling consisted of two parts (1) ordinary convection, and (2) direct effect of the fluid stream. His equation then is of the form

$$H = A\theta + BV\theta.$$

A and B are constants.

The first term is therefore the rate of cooling when $V = 0$.

JORDAN⁽¹³⁾ has verified this for hot-air currents losing heat to metal tubes. STANTON⁽²⁹⁾ found, in a research on the convection of heat in a liquid moving through a tube with a turbulent motion, that the index of V in the above formula was slightly less than unity.

JORDAN used velocities up to 20 lbs. of air per sq. ft. per second, that is equivalent to a velocity of 7.4 metres per second. At these velocities our curve resembles JORDAN'S.

In our experiments we were fortunate in having at our disposal means of obtaining velocities ranging up to about 90 metres per second or 200 miles an hour. The results obtained are illustrated in a striking way in the curves in figs. 8 and 9.

In order to bring out the influence of velocity we have treated the curve as being of the form $H/\theta = a + bf(V)$ where a and b are constant. This assumes then that $H = a\theta + b \cdot \theta \cdot f(V)$: our purpose being to determine the nature of the function V .

* CRICHTON MITCHELL verified the law up to 200° C. and a velocity of 1000 metres per minute, 'Roy. Soc. Edin. Trans.' 1900, 40, p. 39.

MEASUREMENT OF THE RATE OF HEAT-LOSS AT BODY TEMPERATURE, ETC. 201

One very striking fact is that in the first term $a\theta$ of this expression the curve gives the same value of a as the slope of the total heat-loss curve, fig. 7, in our experiments

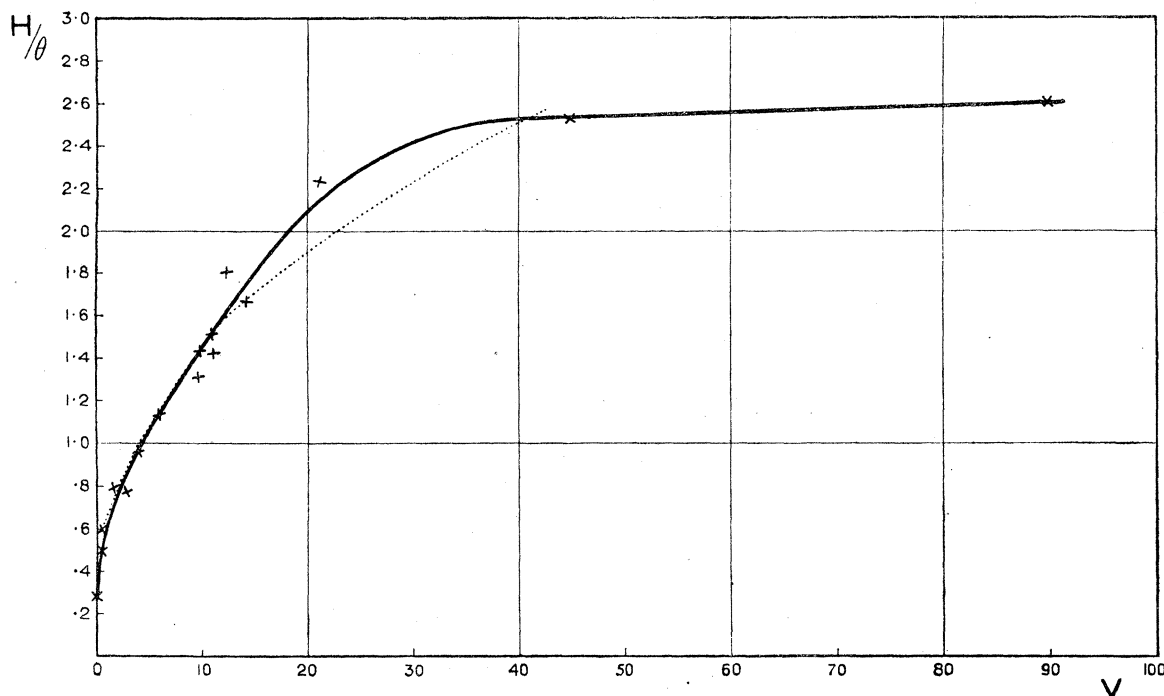

Fig. 8. Effect of velocity on total heat-loss. (Convection and radiation.)

— Experimental curve.

..... Graph of $H/\theta = 0.27 + 0.36\sqrt{V}$.

H = heat lost in millicalories per square centimetre per second.

$\theta = (36.5 - t)^\circ \text{C}$. where t = temperature of enclosure.

V = velocity of air current in metres per second.

in quiet air. We may take it then that the first term $a\theta$ represents radiation and, what we may call, diffusive convection in still air. So that taking the equation in the form $H/\theta = a + bf(V)$ we may be sure that the second term includes only the effect of

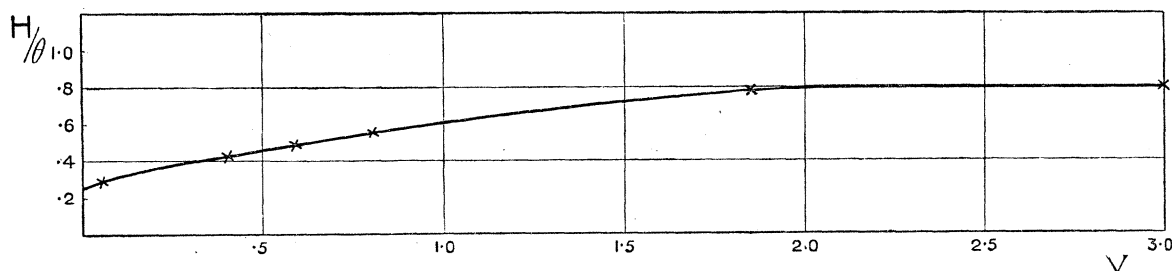

Fig. 9.

velocity, and that it is zero when the velocity is zero. It ought to be mentioned here that the velocities we used were all in excess of the critical velocity, and therefore the motion was turbulent. And we rather think, according to the dimensions of COMPAN'S

apparatus that the motion in his case was also turbulent, though he considers his results as verifying BOUSSINESQ'S law for a non-turbulent flow. We believe that the confusion is cleared up by our results. A study of the curves in figs. 8 and 9 reveals the fact that the law of OSBORNE REYNOLDS for turbulent motion is roughly true for a range up to about 1.5 metres per second (about 3.5 miles per hour), and, with a different set of constants, it also applies over the range included between 1.5 metres per second and 20 metres per second (*i.e.*, from 3.5 to 4.5 miles per hour). But, by trial, we find that the equation $H/\theta = 0.27 + 0.36\sqrt{V}$ covers all cases up to about 35 metres per second (*i.e.*, about 80 miles an hour). This means that an extended form of BOUSSINESQ'S law, owing to the inclusion of the first term, or an amended form of the law of OSBORNE REYNOLDS where the index of V is 0.5, covers all cases one is likely to meet with in practice. Beyond the limit of 35 metres per second, any additional velocity seems to produce only a very slight increase in the rate of cooling. We may almost say that it is constant up to the limit of our observations, namely, a velocity of about 90 metres per second or 200 miles an hour. This fact may prove of some consolation to those motorists who are prone to exceed the speed limit. We suppose that such high speeds may be attainable in the future and it is well to know that, to the disadvantage perhaps of the petrol motor and the advantage of the human body, the rate of cooling will then have attained a constant value, at least as far as convection, in its loosest sense, can affect it. (But see the section on evaporation below.)

The coincidence of the experimental curve and the graph of the equation $H/\theta = 0.27 + 0.36\sqrt{V}$ up to velocities of about 16 metres per second (or 35 miles an hour) justifies our claim that the dry kata-thermometer can be successfully employed as an anemometer measuring the mean velocity of the wind. Table IV. is computed by means of this formula.

The velocity measured, however, is that which exists during the few seconds that the instrument is cooling. The flow of wind in an open space is scarcely ever steady—it blows in gusts; hence to get an average measure of its velocity several readings should be taken with the kata-thermometer. As the kata-thermometer is affected by the least movement of the air and by eddies, it is the most sensitive anemometer.

The velocity of the wind can be determined by means of the following Table IV. :—

TABLE IV.

H/θ .	Velocity, metres per second.	Miles per hour.
0.63	1	2.2
0.78	2	4.4
0.89	3	6.6
0.99	4	8.8
1.10	5	11.0
1.40	10	22
2.10	20	44

MEASUREMENT OF THE RATE OF HEAT-LOSS AT BODY TEMPERATURE, ETC. 203

Where H is the reading of the dry kata shaded from the sun or other source of radiant heat and exposed to the wind in millicalories per square centimetre per second and $\theta = 36.5 - t$, where

$36.5 =$ mean body temperature,

$t =$ temperature of the air in degrees Centigrade.

Values not given in the table may be obtained by interpolating by proportional differences.

For example :—Suppose H/θ works out to be 0.82. Then from table

H/θ .	Velocity.
0.78	4.4
0.89	6.6 miles per hour.
<hr style="width: 50%; margin: 0 auto;"/>	<hr style="width: 50%; margin: 0 auto;"/>
Increase . . . 0.11	2.2
<hr style="width: 50%; margin: 0 auto;"/>	<hr style="width: 50%; margin: 0 auto;"/>

Since 0.82 is an increase of 0.04 over 0.78 the corresponding velocity increase is $\frac{2.2}{0.11} \times 0.04 = 0.8$.

The required velocity is therefore 5.2 miles per hour.

Radiation.

In an attempt to estimate the heat-loss due to radiation and separate this from that due to convection we enclosed the kata-thermometer in a tube and evacuated this as perfectly as possible. We used a quartz tube at first having regard to its transparency, but comparing quartz and glass we found a glass tube gave us readings of much the same value, and glass was much easier to handle. In their transparency to infra-red rays, with which we were dealing, the quartz and glass seemed to be much the same. Triangular pieces of wire, with glass beads on them, were loosely attached to the stem of the kata-thermometer so as to prevent this touching the sides of the tube. The inside of the tube was blackened with a dull black to prevent reflection. A vacuum was made first with the help of a Geryk, and then of a mercury pump using a phosphorous pentoxide drying tube. A Macleod gauge was used for estimating the vacuum in millionths of an atmosphere. All the connections were made of glass with the help of a blow-pipe and flame.

CROOKES⁽⁴⁾ has shown that the last few millionths of an atmosphere must be reduced to secure the final removal of heat-loss due to convection. We produced vacua of one millionth or less of an atmosphere, and as we found sealing off the tube inevitably caused a slight leakage through softening of the glass, we used a mercury tap and after closing this, cut the vacuum tube, together with the tap, from the pump. After adopting this procedure we obtained readings of the same value before as after removal of the vacuum tube from the pump. The kata-thermometer within the vacuum tube

was heated by a source of radiant heat, *e.g.*, gas fire; the vacuum tube was then cooled by immersion in water (at the same temperature as the observation chamber), and after drying, placed in still air within the chamber. The rate of cooling from 100°–95° was then noted and compared with that of the kata-thermometer exposed to still air at the same temperature. The difference gave us approximately the rate of cooling due to convection. There is an unavoidable error due to the fact that the kata heats the wall of the vacuum tube and thus the kata is surrounded in part by an enclosure warmer than the walls of the chamber. This error naturally will be greater when the chamber is cold. Table V. gives results as calculated and found by direct measurement:—

TABLE V.

Air temperature.	Total H.	Convection calculated by formula.	Radiation.	STEFAN'S formula.	Radiation found by direct measurement.	
26·5	2·65	1·21	1·44	1·41	1·38	1·43
20	4·45	2·15	2·30	2·01	2·20	
16·5	5·35	2·85	2·50	2·46	2·45	
6·5	8·10	4·51	3·60	3·45	3·20	

We conclude that in still air at ordinary room temperature the rate of cooling at body temperature is due as much to radiation as to convection, when the walls of the observation chamber are at the same temperature as the air inside it.

Evaporation.

Meteorologists, physiologists and physicists have manifested an absorbing interest and expended an incalculable amount of energy in researches on the phenomenon of evaporation. Articles by Mrs. GRACE LIVINGSTON in the 'Monthly Weather Review'⁽¹⁹⁾ of the United States Bureau of Agriculture for 1908 and 1909 contains a complete annotated bibliography to date of some hundreds of papers on the subject. Evaporation from surfaces of ponds, from water in tanks, and beakers and tubes, and the human body seems to have been studied almost to the point of exhaustion. Going through these papers one meets with accounts of elaborate experiments with evaporimeters of all sorts of designs, only slightly less ingenious than the mathematical formulæ derived from them to express the "law of evaporation." The said law, however, appears to have successfully evaded its pursuers.

The subject is one of inherent difficulty, both from the experimental and theoretical standpoint, for evaporation is only a statistical record of the molecules which "go out of bounds," that is the average difference between the molecules which are shot out from the water surface and the number that return. It is subject to the ordinary law of diffusion, and it is a phenomenon which is particularly sensitive to air motion, or wind, and to change in temperature.

It seems to have been the endeavour of previous workers to determine the rate of transference of matter from water to air, and to call that the rate of evaporation. This has several disadvantages. It is slow and therefore uncertain. Because while the measurement is being made considerable changes may take place in the vapour present in the surrounding atmosphere. Further, it takes no direct account of temperature, and so in interpreting the results one has to keep in mind that the quantity of liquid evaporated is an unknown function of both temperature and vapour pressure. This fact alone accounts for the complexity of many of the empirical formulæ which have been proposed. Then there is the velocity of the wind, in addition to possible free convection currents: introducing further complications to both experiment and theory.

The following are samples of formulæ which have been proposed to represent the relation between evaporation, vapour pressure and wind velocity.

Full references are given in the bibliography at the end.

The notation adopted is:

E = rate of evaporation, *i.e.*, maximum evaporated per second.

F = maximum vapour pressure at surface of liquid.

f = vapour pressure in the atmosphere.

T = absolute temperature.

B = barometric pressure.

V = velocity of wind.

Other symbols are constants.

$$E = C(F-f)(1+\alpha V). \quad (\text{DALTON}).$$

$$E = \frac{C}{T \left(\frac{df}{dt} + A \cdot B \right)} \cdot (F-f)(1+\alpha BV). \quad (\text{WEILENMANN}^{(34)}).$$

$$E = [\alpha(F-f) + b(F-f)^2](1+0.67V^{1/2}). \quad (\text{FITZGERALD}^{(5)}).$$

$$E = \alpha(F-f) + b[(F-f)^2 + 10(F-f)]^{1/2}(V^2 + 17V)^{1/2}. \quad (\text{HOUDAILLE}^{(12)}).$$

$$E = KF^{1/3} \text{ (comparative formulæ for different liquids, } K \text{ depending on the nature of the liquid).} \quad (\text{VAILLANT}^{(32)}).$$

It will be seen that most of these formulæ assume DALTON'S law for evaporation in still air, namely that it is proportional to $(F-f)$. But if we keep in mind that the phenomenon is subject to the laws of diffusion, and if we recollect further that (1) the differential equations representing diffusion and thermal conduction are similar in form, DALTON'S law can only be strictly true for a very small difference of vapour pressures. It is clear, therefore, that when such equations are integrated the total rate of evaporation should be proportional to some power of $(F-f)$, just as the total rate of convection is proportional to a power of the temperature excess. To bring out the analogy some writers have proposed the term "saturation deficit" for the

expression ($F-f$). We call further attention to this point in the section dealing with the "degree of comfort" of the atmosphere.

Experiments on Evaporation.

To investigate the effect of varying vapour pressure we introduced into the chamber one of our instruments, contrived for measuring the dew point, in addition to the wet kata-thermometer and the wet- and dry-bulb thermometers. The jacket was then filled with a freezing mixture, powdered ice and salt, and readings of the various instruments were made in the cooled chamber. The chamber was then gradually warmed up, and successive readings taken at different temperatures up to temperatures near body temperature. In some experiments basins containing concentrated sulphuric acid were placed overnight in the chamber, and the air thus dried before the experiment. In other experiments boiling water was introduced, allowed to spread over the bottom of the chamber and give off steam, and then drained off. We thus obtained atmospheres nearly saturated with moisture.

Determination of the Dew Point.

To determine the dew point we contrived two modified and very sensitive forms of REGNAULT'S instrument. These gave us concordant results.

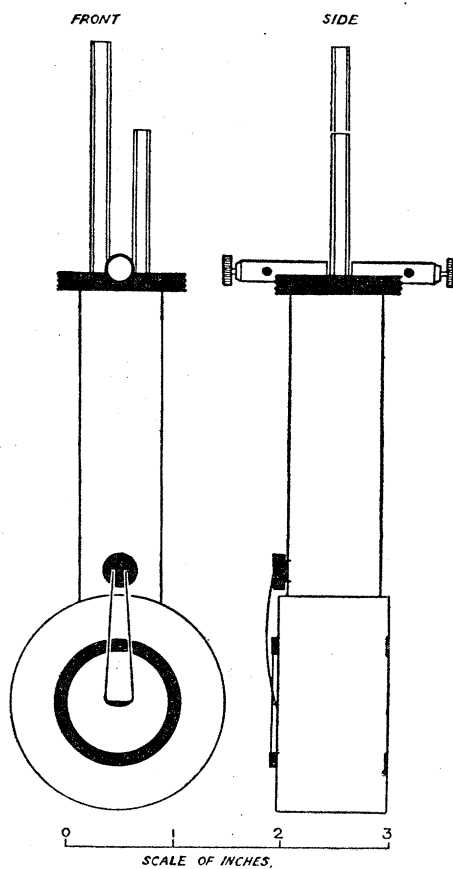

Fig. 10.

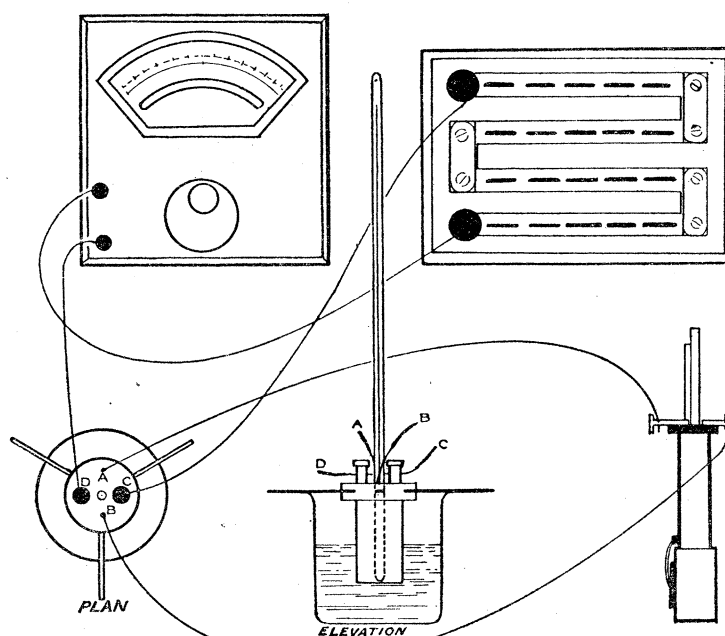

Fig. 11.

The first form consists of a small metal cylindrical box with polished silvered faces (fig. 10); on one face there was attached a thermo-electric junction, made of constantine and iron. The opposite face was observed for the deposit of dew. Two tubes led into the box, through which ether could be introduced, and air, to evaporate the ether, blown. In this way the box was cooled till dew was deposited on the faces. The thermo-electric junction was put in circuit with a galvanometer (PAUL) together with a similar junction placed in a metal pot which was immersed in water at room temperature (fig. 11). This box was filled with oil, and a thermometer standing in the oil indicated its temperature. A resistance box was put in the circuit, and so arranged that three divisions of the galvanometer scale indicated a difference of one degree Centigrade between the thermo-electric junctions.

To facilitate the exact observation of the dew point, the silvered cylindrical box was enclosed in an ebonite cylinder, and this again in a silvered metal cylinder. The face thus presented for observation the inner disc of silver, surrounded by a ring of ebonite, and this again by a ring of silver. The contrast between the polished metal of the inner surface and outer ring allowed us to determine the first sign of dullness due to deposit of dew. As the thermo-electric junction was a part of the surface on which dew formed, the reading of the temperature of the dew point was exact.

The second form of instrument for obtaining the dew point is shown in fig. 12. It consists of a polished metal box with two tubes led into it for the introduction of ether, and blowing of air to cool the ether. In front of this box is a slot. Fitted snugly into the slot is a flat-bulbed sensitive thermometer, such as is used for taking skin temperatures. The bulb of this instrument is covered with silver foil. By this means the thermometer is firmly wedged into the slot. A metallic contact is thus secured between the box and the thermometer, and the silver foil affords a suitable surface for observing the formation of dew which may be contrasted with that of the box. The dew first forms on the box, and then immediately after begins to dull the foil, which is at the same temperature as the thermometer.

The sharp reading of the dew point by these instruments depends on the suitable illuminating of the surfaces by means of a laryngoscopic mirror. Such illumination must not be too brilliant.

Theoretical Considerations.

In order that our method of experiment and of displaying our results should be quite free from any suspicion of bias, we carried out our determinations as already

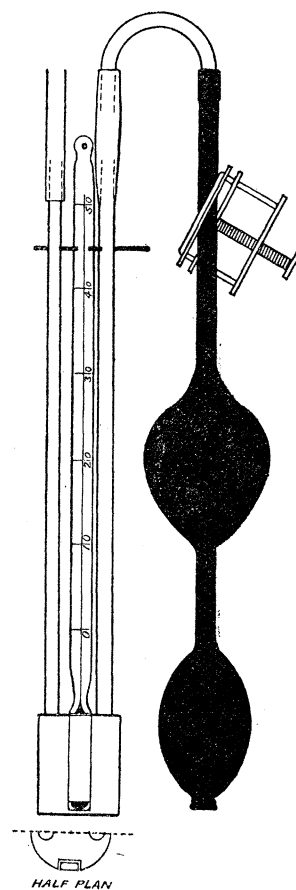

Fig. 12.

mentioned (Table I.), under all possible combinations of temperature and humidity (fig. 13), and then plotted our readings against the saturation deficit.

The resulting curve (fig. 14) is very striking. We took some hundreds of readings, and only a few had to be rejected on account of experimental error. The observations—and this is true throughout all sections of this paper—were made with different

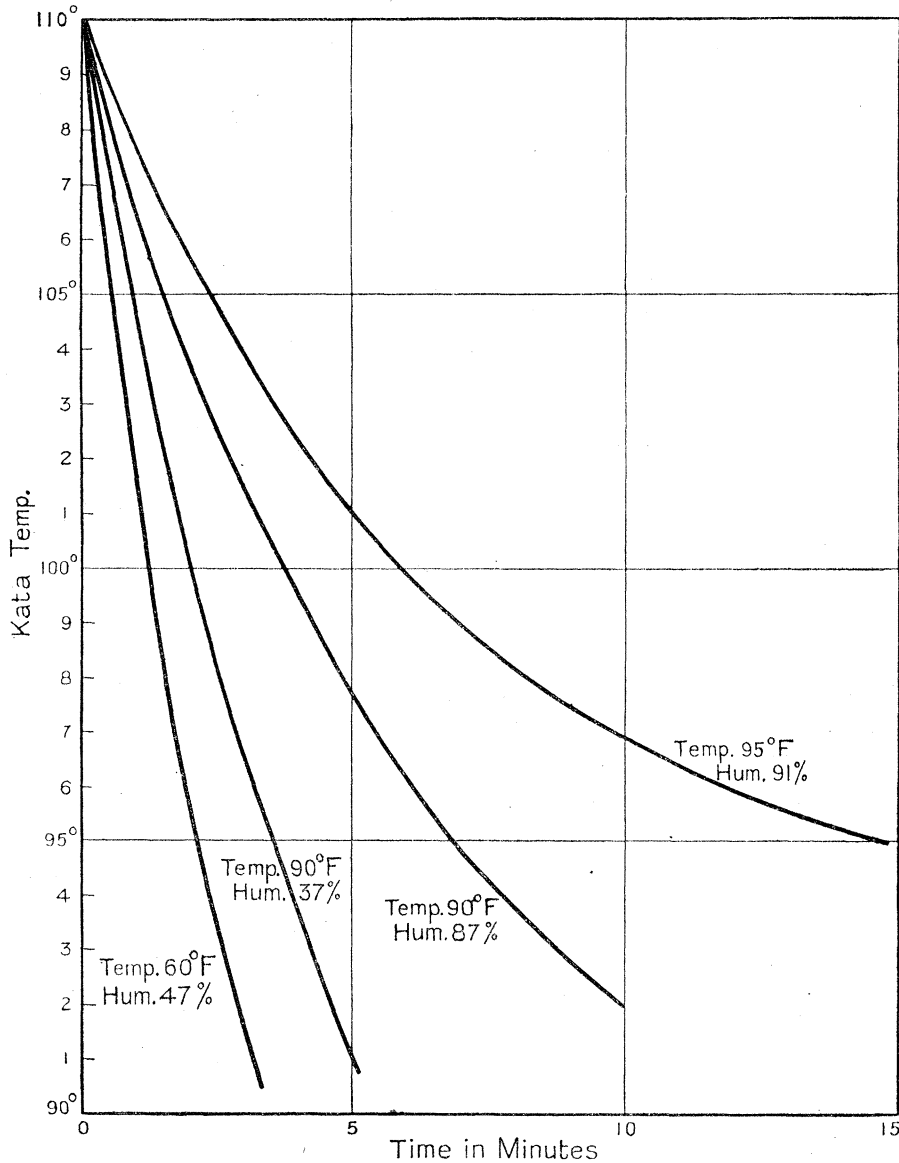

Fig. 13. Wet kata cooling curves for different temperatures, and humidity of enclosure.

kata-thermometers, at different times, and by different persons. It is proved above that the heat lost by convection is the same in air as in an atmosphere of water vapour. Our experiments confirm this. *We are therefore justified in calculating the heat lost by evaporation as the difference between the heat lost by the wet and dry kata-thermometers under the same conditions.* The quantity which we have

measured is therefore the rate of loss of heat by evaporation per square centimetre per second. This, it is clear, is the product of the mass of water evaporated per square centimetre per second, and the latent heat of water vapour at the temperature of the wet bulb (in our case $36^{\circ}5$ C.).

The manner in which evaporation, as generally understood, depends on the temperature of the water surface will then be involved in our measurements (since the latent heat is a function of that temperature) without our having to make any guesses as to its nature. The relation between the latent heat and temperature, however, being known with some degree of accuracy, the temperature factor is quite easily introduced. If F is the maximum vapour pressure at the surface of the wet

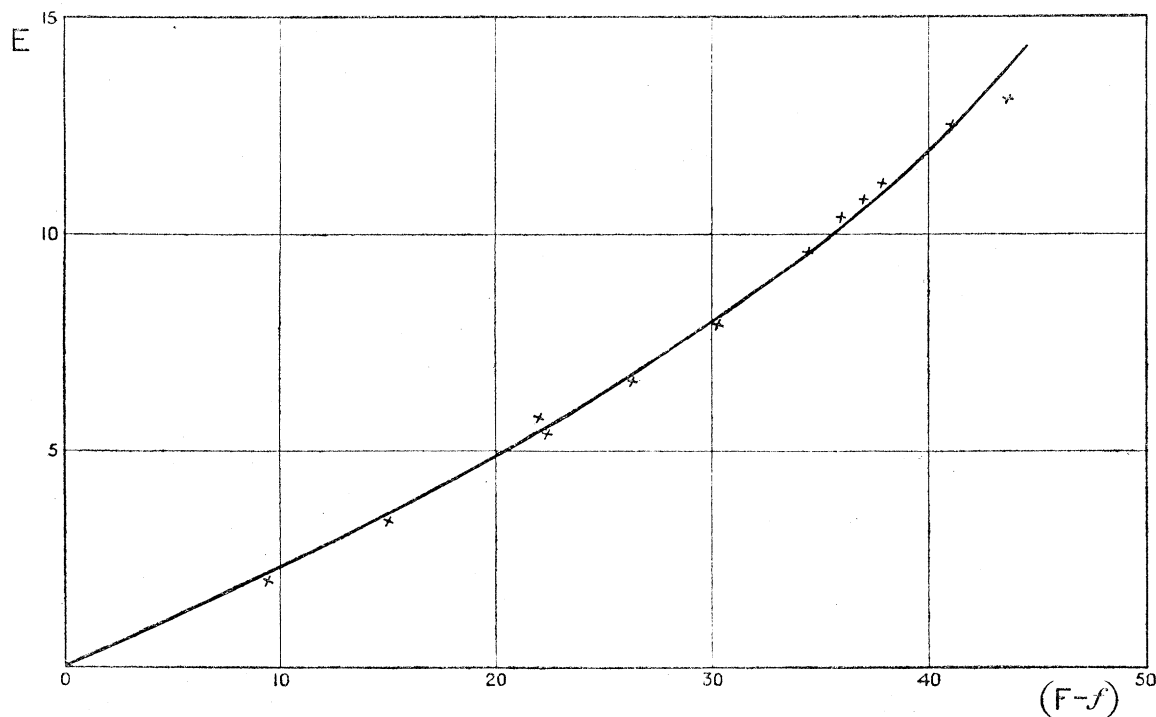

Fig. 14.

bulb, and f is the vapour pressure in the air, then the heat lost in quiet air, by the wet kata-thermometer in millicalories per square centimetre per second is

$$H = 0.27\theta + 0.085 (F-f)^{4/3}.$$

The first term is due to convection and radiation and the second to evaporation. So that the rate of evaporative loss is

$$E = 0.085 (F-f)^{4/3},$$

this is the equation of the curve in fig. 14.

Hence, if m = mass of water in milligrammes evaporated per square centimetre per second,

$$L = \text{latent heat as usually expressed,}$$

$$mL = 0.085 (F-f)^{4/3}.$$

E. H. GRIFFITHS found for L between 30° and 40° C.

$$\text{also } L = 596.73 - 0.601t,$$

Therefore, if $F = 45.6$ mm. at 36°·5 C.

$$t = 36^{\circ}\cdot 5 \text{ C.}$$

$$m = \frac{0.085(45.6-f)^{1/3}}{596.73-0.601t} = \frac{0.085(45.6-f)^{1/3}}{574.8} = 0.00015(45.6-f)^{1/3}.$$

This is similar in form to the equation of VAILLANT, who also attacked the problem without assuming DALTON'S law.

Taking the formula representing our experiments and re-writing it, we get

$$45.6-f = 6.369E^{3/4}.$$

$$f = 45.6 - 6.369E^{3/4}.$$

This gives us a ready means of determining the vapour pressure in the air by means of the kata-thermometer. It is only necessary to take readings in the manner hitherto described, in a chamber as large as ours, the walls of which are at the same temperature as the air, and the vapour pressure can be calculated by means of the formulæ or read off from a table constructed from it. Such a table is given below.*

E = difference between dry and wet kata rate of heat-loss readings at 36°·5 C. in millicalories per square centimetre per second.

f = vapour pressure in the atmosphere in millimetres of mercury.

TABLE VI.—Vapour Pressures Estimated by Kata-Thermometer.

Difference in millicalories between wet and dry kata readings.	Vapour pressure in millimetres of mercury.
1	39.3
2	34.9
3	31.1
4	27.6
5	24.3
6	21.2
7	18.2
8	15.3
9	12.5
10	9.8
11	7.2
12	4.7
13	2.1

The first column gives the difference, in millicalories per square centimetre per second, between the rates of cooling of wet and dry kata-thermometer when protected

* There is a difficulty in using the method for determining the vapour pressure of the atmosphere owing to the fact that the readings must be taken in a chamber quite free from draught. We find, on shutting up a chamber, the vapour pressure at once begins to rise owing to water absorbed on the walls of the chamber being given off as vapour and increasing the saturation of the stagnant air. The drying power of moving air is thus exemplified.

from draughts. The second column gives the corresponding vapour pressure in the atmosphere.

N.B.—In order to use this table it is advisable to work out the rates of cooling correct to the first place of decimals.

Example:—

Suppose the evaporation works out	6·4
Then vapour pressure corresponding to	6 = 21·2
" " " "	7 = 18·2
	<hr style="width: 100%;"/>
Difference	3·0
	<hr style="width: 100%;"/>
Therefore correction to be subtracted	= 0·4 × 3 = 1·2
,, vapour pressure corresponding to	6·4 = 21·2 - 1·2 = 20

*Influence of Velocity of Wind on Evaporation.**

These readings were taken in a manner similar to that described for the dry readings. The results obtained are plotted out in fig. 15.

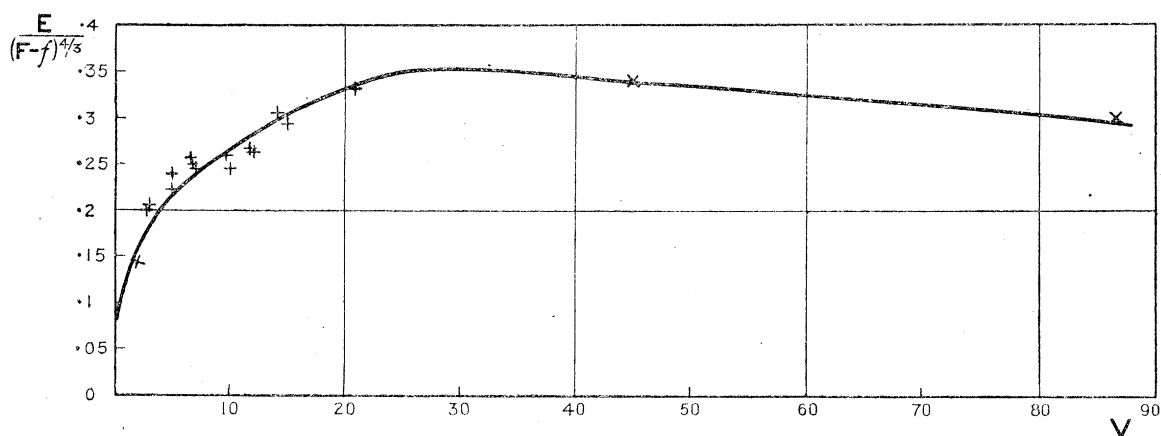

Fig. 15.

Theoretical Considerations.—Examination of the formulæ of other workers—some of which have been already quoted—suggested drawing the graph between the quantities $E/(F-f)^{1/3}$ and V in a manner similar to the one adopted in treating the case of convection. It will be observed that the curve cuts the E axis at the point corresponding to the case of zero velocity. Up to a velocity of 25 metres per second (55 miles per hour) the curve is very well represented by the equation

$$E/(F-f)^{1/3} = 0.085 + 0.056 \sqrt{V}.$$

* An account of earlier work on this subject is given by RUSSELL, 'Monthly Weather Review,' 1888, of later work by BIGELOW, 'Monthly Weather Review,' 1907-9. H. T. BROWN and W. E. WILSON have studied the thermal emissivity of leaves using platinum resistance thermometers and clothing these with the leaves. They have thus determined the water transpired per unit area and time, and the effect of the velocity of the air on the same. For their method see 'Roy. Soc. Proc.,' 1905, B, 76, p. 122.

Above this limit, the evaporation seems by our curve to begin to diminish with increased velocity, but it is quite safe to say that it has attained a practically steady volume. For speeds up to 4 metres per second, it is proportional to the velocity—a result which was also observed by HOUDAILLE.

The equation which represents our results can then be written

$$E = (F-f)^{1/3} (0.085 + 0.056 \sqrt{V}).$$

And therefore the complete equations for the wet kata-thermometer, for the range of velocities indicated, is

$$H_w = (0.27 + 0.36\sqrt{V})\theta + (0.085 + 0.056\sqrt{V})(F-f)^{1/3}.$$

An examination of this formula and of the corresponding curve shows that the acceleration of cooling is very much greater during the first 5 metres per second (or 10 miles per hour) of speed diminishing gradually to a zero value at high wind velocities.

We recognise, of course, that the formulæ we have given above are empirical, and that such formulæ are often more or less elegant ways of expressing our ignorance of the real nature of the phenomenon investigated. This arises from the limitations of the experimental methods adopted and the range covered by them. On the other hand empirical formulæ do sometimes suggest new lines of attack. Further researches are required into the effect of other factors—such as pressure and electric condition of the atmosphere—to be able to build up an approximate theory of evaporation.

TABLE VII.—Effect of Wind on Convection and Evaporation.

Dry kata, H.	θ .	$\frac{H}{\theta}$.	Wet kata, H.	$E = H' - H$.	f .	$\frac{E}{(F-f)^{1/3}}$.	V.
8.15	5	1.64	40	31.85	12	0.307	14
8.35	4.8	1.74	33.6	25.25	12.7	0.245	10
12.10	8.1	1.50	43.5	31.40	12.5	0.302	15
5.43	4.9	1.11	32.4	26.97	13.36	0.26	6.5
4.82	5.0	0.964	29.7	24.88	13.03	0.24	4.4
4.75	5.8	0.82	26	21.25	13.6	0.205	2.9
5.35	5.0	1.07	26	20.65	18	0.25	6.5
4.6	3.6	1.28	26.4	21.8	18.6	0.265	11.7
4.1	2.9	1.42	28.6	24.5	18.6	0.297	15
9.24	9.5	0.975	31.6	22.36	14.34	0.22	4.9
11.2	9.6	1.17	36.1	24.9	15.18	0.247	7
7.77	9.8	7.95	27.1	19.33	13.0	0.192	2.8
21	26.6	0.793	40.5	19.5	6.23	0.146	1.85
12.95	26.2	0.50	25.9	24.4	6.4	0.098	0.585
11.4	25.8	0.442	25.9	14.4	6.5	0.108	0.4
50	19.2	2.6	88	38	6.4	0.29	87
47.8	19	2.32	91.5	43.7	6.2	0.336	45
44.5	19.6	2.27	89.5	45	6.13	0.334	21
28.6	20	1.43	63.5	34.9	5.9	0.256	9.7

In warm atmospheres the wet-bulb temperature is a far better indicator of conditions of comfort than the dry bulb. Temperatures of 80°–90° F. may be quite pleasant if the air is sufficiently dry and the wet-bulb temperature relatively low. A wet-bulb temperature over 70° F. in the comparatively still air of rooms and factories diminishes comfort and working power, and great attention is paid now to wet-bulb readings, particularly in spinning mills and weaving sheds where artificial humidity is used ⁽⁶⁾, ⁽⁹⁾, ⁽¹⁰⁾, ⁽¹¹⁾, ⁽²⁵⁾. The adequate movement of the air makes a high wet-bulb temperature much less oppressive, and thus by ensuring sufficient movement a humidity can be secured for trade purposes, which otherwise would be uncomfortable and deleterious to workpeople. Prof. CADMAN says concerning work in mines that from about 25° C. (77° F.) wet-bulb reading, exertion begins to be accompanied by depression, and disinclination to work increases rapidly with an increasing wet-bulb temperature. At 27°·8 C. (82° F.) “if clothes be removed and maximum body surface exposed, work can be done providing current of air is available.” At 29°·4 C. (85° F.) “only light work is possible.” At 35° C. (95° F.) “work becomes impossible.” As the wet kata-thermometer takes account both of absolute humidity and of air movement, it affords an instrument by which a comfortable rate of cooling can be standardised. For regulating the humidity and ventilation then, the wet kata-thermometer seems to us to be superior to the wet- and dry-bulb thermometer.*

It would seem probable that the unpleasantly cold sensation which arises from mist on a cool day, is due to the particles of cold water coming in contact with the skin and cooling the nerve endings at the spots sensitive to cold. The water particles owing to their far greater conductivity relative to dry air, and owing to the latent heat required for their evaporation, must increase the difference of temperature between the point of contact and the deeper layer of the skin warmed by the blood. Kata-thermometer measurements show that (owing to the absence of wind) the rate of cooling is not great on a calm misty morning; therefore the cutaneous blood vessels are not constricted as they would be on a cool windy day. Temperature difference which stimulates the nerve endings is thus intensified.

We have placed a thin band of copper round the kata-thermometer and attached a thermo-electric junction to this. We have then measured the rate of cooling both in the graduated stem of the kata-thermometer, and by the thermo-electric junction on its surface. In a saturated still atmosphere we find the thermo-electric junction indicates a cooler temperature than the kata-thermometer does. In other words, there is a greater temperature difference between the surface

* An example will make this clear :—

	Wet bulb. ° F.	Dry bulb. ° F.	Wet kata. H.	Dry kata. H.
Stagnant machine shop	61	72	15	4·6
Foundry, radiant heat and cool air from large louvres in roof and walls	60	72	24	7·3

and body of the kata-thermometer than there is in dry air. We thus find a confirmation of our view of the cause of the cold feeling of cool moist air.

If the kata-thermometer is placed in the chamber saturated with moisture at a temperature above that of the kata dew is of course deposited upon the kata, and rapidly warms it up. Similarly on coming from an outside air into a warm moist room dew is deposited on the clothes imparting its latent heat of evaporation to them.

The adequate transpiration of water from the skin must be of the greatest importance to the nutrition not only of the skin but of deeper parts, as the transpiration entails a flow of lymph from the blood vessels, and a determination of lymph with all its nutritive properties to the transpiring tissues.

The aches and pains, so called "rheumatism," felt by so many when the weather changes from dry to cold humid conditions, and felt by those returning from tropical climates to England in winter time, must be studied from the point of view of transpiration and alterations in heat-loss and metabolism. Rheumatism of nerve, muscle or joint probably has had its ultimate cause in disordered metabolism produced by diet, frigerism, overstrain, or some infectious disease. The metabolism of the part being on the border line of deficiency, a change of weather may be the exciting cause of the rheumatic pain by altering the temperature and blood supply of and transpiration of lymph through the part.

Estimating the Degree of Comfort of the Atmosphere.

In addition to the inherent difficulties of the problem of the rate of cooling of the human body—many of which are interestingly discussed by G. H. KNIBBS⁽¹⁸⁾—there exists amongst a large number of meteorologists, physiologists, physicists and ventilating engineers, an unaccountable affection and reverence for the quantity called "relative humidity." One recent writer in the 'Journal of the Dublin Philosophical Society' expresses his astonishment that many of the formulæ suggested by different people for the rate of evaporation altogether omit any reference to "relative humidity," and even writers of standard works well known for the accuracy of the information they convey, have helped to attach undue importance to the terms by such statements as "our sensations of dryness and dampness depend rather upon this factor than upon the absolute quantity of vapour present."

Some meteorological reports devote many columns to record the value of both the "relative humidity" and the vapour pressure. This superstition—for it can hardly be called anything else, since it has no experimental foundation—has crystallised into a dogma that "relative humidity" must be kept at 75 per cent., otherwise the air is said to be too dry. Elaborate schemes for moistening the air in the House of Commons have been proposed with this end in view.* In America the fallacy has led

* In the House of Commons the rate of cooling at feet level is 50 per cent. (or more) greater than at head level, while the thermometer shows a uniform temperature; the members are given cold feet and hot heads by the system of ventilation—an upcast through a perforated floor.

Prof. WARD to write in the 'Monthly Weather Review' (1908) that he finds it necessary to evaporate 33 gallons of water per day to maintain the air in a certain room at 75 per cent. humidity. JEFFERSON, in the same periodical (1909), following in the same track, tested the air in a number of schools and came to the conclusion that 200 gallons per day per 100 children should be evaporated to keep the air at the right relative humidity! It is difficult to believe that any one could advance such proposals seriously; the only result to be expected from putting them into execution would be aggravation of the discomfort complained of. For diminished evaporation from the skin and respiratory passages would decrease the rate of cooling still further, thereby diminishing the cutaneous stimulation so necessary for comfort, producing congestion of the sensitive membranes lining the nose and throat. In addition to this there would be distillation of water vapour on to the cold windows and walls.

J. VINCENT⁽³³⁾, on the other hand, goes to the other extreme, and denies absolutely that the humidity of the air has anything at all to do with our feelings—at least in a temperate climate. He works out an equation to represent his results in terms of skin temperature:

$$T = 26.5 + 0.3t + 0.2d - 1.2v;$$

t = temperature of air; d = excess of temperature registered by actinometer over that of air; v = velocity of wind. It seems most probable, however, that the variation of humidity was so small in his observations that its effect is probably included in the constant term of his formula. Other workers, such as HARRINGTON and TYLER, have endeavoured to find a means of expressing sensations in terms of temperature. We are convinced, however, that they are following a false track. The form of the equation of the wet kata-thermometer suggests that there may exist a balance between the temperature of the air, the vapour pressure and the velocity, such that each may be varied within certain limits and still keep the rate of loss of heat—on which our sense of comfort depends—the same. This receives striking confirmation from some observations carried out by Dr. HENRIQUE MORIZE, Director of the Rio Janeiro Observatory⁽²²⁾. He kept a record, spread over two years, of the temperature of the air, the relative humidity and his own personal sensations. The results are published in his report for 1913. One of the present writers (O. W. G.) has arranged his curves, and applied the wet kata-thermometer formula to readings taken from them—Table VIII. shows the values thus obtained.

A mean value of one metre per second has been taken for the wind velocity which MORIZE only records as being less than three metres per second. An examination of the table at once suggests how a scale of comfort could be established by means of the wet kata-thermometer. In order to examine this point three other tables are added constructed from published data. The Congo values are calculated from readings quoted in MORIZE'S report, and the agreement between the scale number 17.1 and

that of 17·8 deduced from MORIZE'S readings under corresponding conditions we venture to suggest is something more than a coincidence. The next set of figures are taken from W. A. OSBORNE'S paper⁽²⁴⁾, and the value of H calculated as before. The slight variations which occur are undoubtedly due to the uncertainty attached to the anemometer readings which OSBORNE says were not true measures of the velocity. A further test of the possibility of forming a scale of comfort is afforded by some wet kata readings taken by one of the authors during the present year.

TABLE VIII.—MORIZE'S Results (Rio Janeiro) Expressed in Kata-Thermometer Units.

Feelings.	<i>t.</i>	<i>θ.</i>	<i>f.</i>	V.	H.	
Comfortable	{ 22 25 28	{ 14·5 11·5 8·5	{ 16·7 13·6 9·8	} Slow movement described as less than 3 metres per second, say, 1 metre per second.	{ 21·2 21·9 21·9 } Mean . . 21·7	
Warm	{ 24 26·8 29	{ 12·5 9·7 7·5	{ 18·3 15·6 12·4		} Slow movement described as less than 3 metres per second, say, 1 metre per second.	{ 19 19·2 19·7 } Mean . . 19·3
Fresh and cool	{ 19·5 18·5	{ 17 18	{ 8·18 14·6			} Slow movement described as less than 3 metres per second, say, 1 metre per second.
Sweating	{ 27 29 31	{ 9·5 7·5 5·5	{ 20 15·5 13	} Slow movement described as less than 3 metres per second, say, 1 metre per second.	{ 17·3 17·9 18·2 } Mean . . 17·8	
MELITOR'S Results (Congo).						
Warm	{ 30 28 26	{ 6·5 8·5 10·5	{ 17 18·3 18·74	} Slow movement described as less than 3 metres per second, say, 1 metre per second.	{ 16·4 17·1 17·7 } Mean . . 17·1	
OSBORNE'S Readings (from Paper II).						
Feelings.	<i>t.</i>	<i>θ.</i>	<i>f.</i>	V in feet per hour.	H.	
"Not at all unpleasant," in a letter to one of the authors.	21·3	15·2	9·6	7960	24	
	23	13·5	7·7	7700	24	
	30	6·5	11·6	7400	18·1	
	28	7·5	13	7600	17·9	
				= 0·68 m.p.s.	Mean . 21	

TABLE VIII. (continued).—O. W. G.'s Readings.

Feelings.	H.
Very pleasant day, April 27, 1915, outdoors	30
June 5, nice breeze, pleasant outdoors	31
May 5, warm, sultry outdoors	17
March 9, indoors 4 feet from gas stove unpleasantly warm	16
January 11, in laboratory, stuffy still air, 6 steam boilers working	11
May 8, very fresh breezy day outdoors	40

A glance at these various tables reveals the fact that for comfort the cooling power of the atmosphere, as determined by the wet kata-thermometer, is probably something between 20 and 30 millicalories per square centimetre per second.* The actual figure will depend on the prevailing climatic conditions, for these determine the standard to which our bodies are tuned. We are more or less adapted to the environment in which we live, and our sense of comfort must bear a close relation to the range of variation of climatic conditions which we usually experience. There is, of course, in addition, the purely personal physiological factor depending on general health, mode of living, &c. It ought to be stated here that all the above tables relate to the resting body. It seems desirable to obtain direct records of kata-thermometer readings and feelings taken by a number of persons in different parts of the world. We have undertaken such an investigation, being helped by many voluntary observers taking readings all over the world.

Fig. 16 illustrates how different combinations of temperature, moisture and wind velocity may produce a sense of comfort ; or a feeling described as being "very fresh." The curves are based on a table of O. W. G.'s readings. This diagram is not final but purely tentative and suggestive, 3 being taken as a comfort standard and 40 as the "very fresh." For example, the line "comp. val. = 4 m.p.s." is represented by the equation

$$3_0 = (0.27 + 0.36\sqrt{V}) \theta + (0.085 + 0.056\sqrt{V})(F - f)^{2/3}.$$

Such lines are, however, limited, as shown by (1) the saturation pressure curve—for the air can never be more than saturated; (2) by a line of minimum vapour pressure—drawn in the diagram in an arbitrary position. It would probably not be quite straight but slightly concave upwards. It represents the lowest vapour pressure experienced at different temperatures in the locality concerned during a year's time. This will depend on the presence of tracts of water, character of vegetation, &c.; (3) a vertical line indicating the critical temperature at which visible

* In a large number of observations made by one of us (L. H.) in munition factories a reading of about 20 was found in shops which felt fresh, and about 15 in shops where the air felt stagnant.

sweat appears, or is on the point of appearing. For at this temperature there is a sudden increase in the evaporation from the skin.

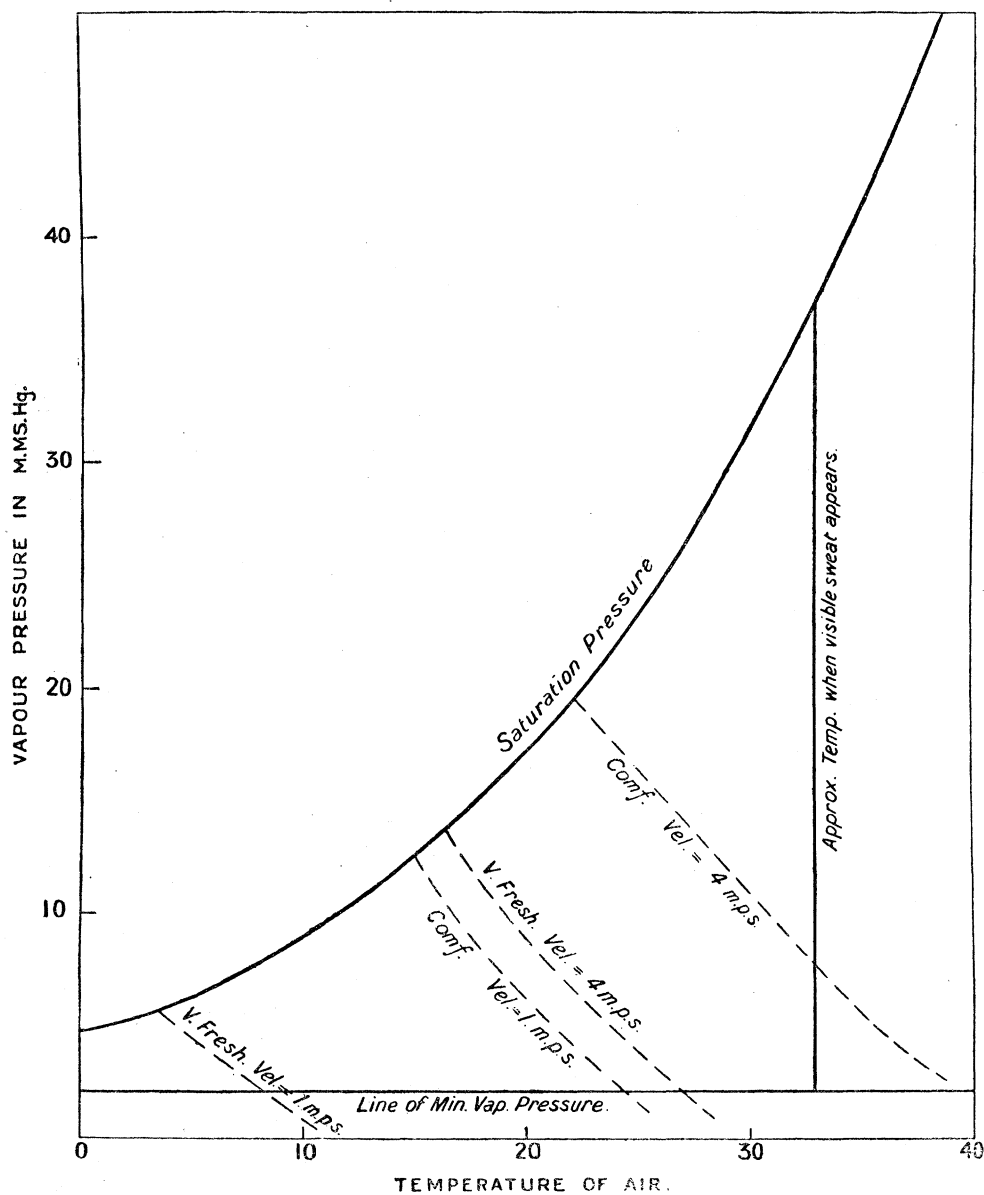

Fig. 16.

Reference to the curve will show that the combinations indicated in the following table will produce comfortable conditions when there is gentle motion of the air:—

Temperature.	Vapour pressure.	Per cent. humidity.
15	12·5	98
16	10	74
17·5	9	60
20	6	34

One other comparison deserves mention. PARRY, the explorer, said that air at a temperature of -44° C. and quiet was pleasant rather than otherwise. Applying our formula to this, and assuming a low velocity of wind, say, 0.25 metre per second, we get $H = 54$ —quite a reasonable figure. If the air were perfectly still—which is improbable—the value works out to be 37.

BIBLIOGRAPHY.

- (1) BOUSSINESQ, J., 'Comptes Rendus,' 1901, CXXXIII., 257; 1905, CXL., 65.
- (2) BRUSH, 'Phil. Mag.,' XLV., 37.
- (3) COMPAN, P., 'Ann. de Chim. et Phys.,' 1902, XXVI., 488.
- (4) CROOKES, W., 'Roy. Soc. Proc.,' 1881, XXXI., .
- (5) FITZGERALD, D., 'Trans. Amer. Soc. Civ. Eng.,' 1886, XV., 581.
- (6) HALDANE, J. S., 'Jour. Hyg.,' 1905, V., 494.
- (7) HARRINGTON, 'Internat. Med. Mag.,' 1894; 'Abstract Amer. Meteor. Jour.,' 1895.
- (8) HEBERDEN, W., 'Phil. Trans. Roy. Soc.,' 1826, Part II., 69.
- (9) HILL, FLACK, &c., 'Smithsonian Miscellaneous Collections,' 1913, LX., No. 23.
- (10) 'Home Office Reports of Departmental Committee on Humidity and Ventilation in Cotton Weaving Sheds,' 1909, 1911.
- (11) 'Home Office Report of Departmental Committee on Humidity and Ventilation in Flax Mills and Linen Factories,' 1914.
- (12) HOUDAILLE, F., 'Comptes Rendus,' 1885, CL., 428; 'Ann. École Nat. Agric. Montpellier,' 1892, VI., 197.
- (13) JORDAN, 'Instit. of Mech. Engineers,' 1909, p. 1317.
- (14) KENNELLY, A. E., WRIGHT, C. A., and VAN BYLEVELT, J. S., 'Amer. Instit. Elec. Eng.,' XXXVIII., 363.
- (15) KENNELLY and SANBORN, *ibid.*, April 24, 1914.
- (16) KING, L. V., 'Trans. Roy. Soc.,' A, 1914, vol. 214, p. 373.
- (17) KISSKALT, 'Arch. f. Hyg.,' 1907, LXIII., 287.
- (18) KNIBBS, G. H., 'Phil. Mag.,' 1912, XXIV., 325.
- (19) LIVINGSTON, Mrs. GRACE, 'Monthly Weather Review,' 1908, pp. 184, 301, 375; 1909, pp. 68, 103, 157, 193, 248.
- (20) LORENZ, L., 'Ann. der Physik,' 1881, XIII., 582.
- (21) MILNE, J. R., 'Journ. Scot. Meteor. Soc.,' 1912; 'Letter to Nature,' May 6, 1915.
- (22) MORIZE, 'Boletim Meteorologico,' Rio Janeiro, 1910.
- (23) MORRIS, J. T., 'Electrician,' 1912, LXIX., 1056.
- (24) OSBORNE, W. A., 'Journ. Physiol.,' 1910, XLI., 345; 1915, XLIX., 133.
- (25) PEMBREY and COLLIS, 'Proc. Physiol. Soc.'; 'Journ. Physiol.,' 1911-12, XLIII., p. xi.
- (26) PETAVEL, 'Phil. Trans. Roy. Soc.,' A, vol. 191, p. 501.

220 MESSRS. L. HILL, O. W. GRIFFITH, AND M. FLACK ON RATE OF HEAT-LOSS, ETC.

- (²⁷) REYNOLDS, OSBORNE, 'Proc. Lit. and Phil. Soc., Manchester,' 1874, XIV., 9.
(²⁸) RUSSELL, A., 'Proc. Phys. Soc.,' 1910, XXII., 432; 'Phil. Mag.,' 1910, XX., 591.
(²⁹) STANTON, T. E., 'Phil. Trans. Roy. Soc.,' A, 1897, vol. 190, p. 67.
(³⁰) SUTTON, J. R., 'Proc. Roy. Dub. Soc.,' 1905, XI., New Series, p. 13.
(³¹) TYLER, "Psycho-Physical Aspect of Climate," 'Monthly Weather Review,' 1907.
(³²) VAILLANT, P., 'Comptes Rendus,' 1910, CL., 213.
(³³) VINCENT, J., 'Annuaire de l'Observ. de Brux.,' 1900, p. 475; 'Annales de l'Observ. de Brux.,' 1906, XX., Part 4.
(³⁴) WEILENMANN, A., 'Schweiz. Met. Beobacht.,' 1877, XII., 268.
-